

# LEAP CONNECT

## Directions for Practice Test Administration

English Language Arts  
Grade 3

**(page is intentionally blank)**

# Table of Contents

Table of Contents .....	3
Purpose.....	4
Materials.....	4
Directions .....	4
Guidelines .....	5
Guidance on Printed Materials .....	5
Selected-Response Items .....	5
Reading Selected-Response Item Example .....	6
Constructed-Response Item.....	10
Procedures for Annotation of Writing CR Item.....	11
Procedures for Transcription of Writing CR Item .....	12
Use of a Scribe for Writing CR Item.....	13
Augmentative and Alternative Communication Guidelines for Writing.....	13
Session 1.....	14
Session 2.....	64
Session 3.....	84
Session 4.....	102

## **Purpose**

The *Directions for Practice Test Administration* (DPTA) provides the Test Administrator (TA) of the LEAP Connect assessments with specific instructions for the administration of this particular test. Each DPTA provides the exact wording of the items to be used by the TA, the materials needed in the preparation of the test, and guidelines for how to present the items to the student.

## **Materials**

Materials needed for the LEAP Connect Test Administration:

1. *Test Administration Manual* (TAM)
2. *Directions for Practice Test Administration* (DPTA)
3. *Procedures for Assessing Students Who Are Visually Impaired, Deaf, or Deaf-Blind*
4. *Grade 3 ELA Practice Test Reference Materials and Writing Stimuli*

## **Directions**

1. **Know and follow all directions for test administration** provided in the TAM, DPTA, and *Procedures for Assessing Students Who Are Visually Impaired, Deaf, or Deaf-Blind*.
2. Be familiar with and utilize the Text to Speech (TTS) as appropriate. The DRC INSIGHT Assessment System includes TTS that will read aloud the text of directions, items, and answer options and will also read aloud standardized descriptive statements for tables, charts, graphs, and timelines.
  - a. This text is read to all students using a consistent rate of reading and tone of voice. If a student wishes to have any or all of the text repeated, click on the Starting Points button (between the Stop and Play/Pause buttons). Then use the mouse to select the starting point (blue circle) just before the text that needs to be repeated.
  - b. To change the volume or speed of the TTS or turn off the follow-along, select the Options button at the top of the screen, then select Audio Settings and adjust as desired.
  - c. If the TTS will not be used, the TA can turn off the volume and the follow-along using the Audio Settings. The TA must read the directions, items, answer option text, and graphic descriptions **exactly as written** using a consistent rate of reading and tone of voice.
3. Be familiar with and utilize the Alternative Text as appropriate. Alternative Text is bracketed and written in italics. Alternative Text is included for students who are blind or have a visual impairment and require graphics to be described. This Alternative Text includes descriptive statements for tables, charts, graphs, and any graphics necessary for appropriate interaction with the items to be described.

## **Guidelines**

1. **Guiding a student response must be deliberately avoided.** Such cueing might include voice, rate of reading, positioning of correct response option, or body language that would suggest a preference or indicate a correct response. To ensure fidelity of test administration, the TA must use a consistent voice, rate of reading, positioning of response options, and body language during oral presentation.
2. If the TTS is not used, the TA may read the directions, item, response options, and graphic descriptions. All text must be read to the students **exactly as written**, (i.e., no paraphrasing or variation of speed to emphasize words in ways that provide hints as to correct or incorrect responses).
3. The Test Administrator (TA) may use statements to **encourage** the student to respond (e.g., “only one more to go,” “just five minutes until a break,” “keep working,” “I like the way you are listening and following directions”), but **does not** indicate either the correct or incorrect response.

## **Guidance on Printed Materials**

*ELA Practice Test Reference Materials and Writing Stimuli* include required graphics and the answer options for each test item. The DPTA will prompt the TA when the required graphics are to be presented to the student. The answer options are included so they can be copied and used as needed (e.g., eye-gaze boards). *ELA Practice Test Reference Materials and Writing Stimuli* are distributed by the School Test Coordinator (STC).

The LEAP Connect ELA Practice Assessment includes one constructed-response writing item at each grade level. Writing Stimuli are provided for the constructed-response item. Writing Stimuli are distributed by the STC. Review the item and prepare materials as needed **prior to the administration** of the constructed-response writing item.

## **Selected-Response Items**

Selected-response items are presented in the following order:

- Item stimulus (which may include a passage, passage part, picture, graphic, or other illustration)
- Item question
- Answer options (which are indicated by radio buttons and presented vertically)

Students independently select a response from the options. Being mindful that students will respond in a variety of ways (e.g., with words, gestures, eye gaze, communication devices, assistive technology, etc.), TAs can enter responses on behalf of the student.

Ensure that Augmentative and Alternative Communication (AAC) and Assistive Technology (AT) used routinely for instruction are available to support the student in communicating responses.

### ***Reading Selected-Response Item Example***

The LEAP Connect assessment items reflect grade-level content presented at varying degrees of complexity. The following item example illustrates a selected-response item and components which support the ways that students with a wide range of learner characteristics are presented with test items. The following item example does not reflect ALL content that is assessed in each grade-level content area and does not represent every degree of complexity.

### **Reading Item Example**

#### **Directions**

**We are going to read informational text about a writer named Mark Twain. He lived a long time ago and wrote books. After we read, you will be asked a question about this writer. Listen for what the author believes about Mark Twain.**

### **The Life and Works of Mark Twain**

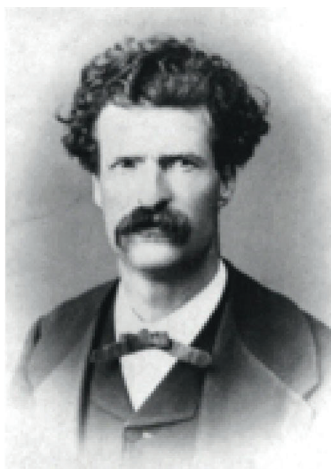

Mark Twain was an American writer.



Twain wrote many books. One of his best known books is The Adventures of Tom Sawyer. The books were set in Missouri. This is where Twain lived.



Twain first began by writing articles for his brother's newspaper. He became well-known after he wrote a funny short story.

*[For students with visual impairment, read “This is a picture of a sailboat.”]*

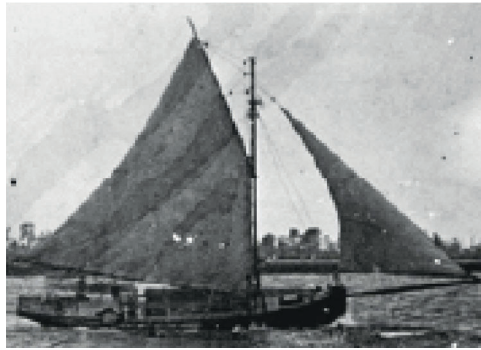

Twain traveled to many places. He visited libraries around the world. Twain became famous.

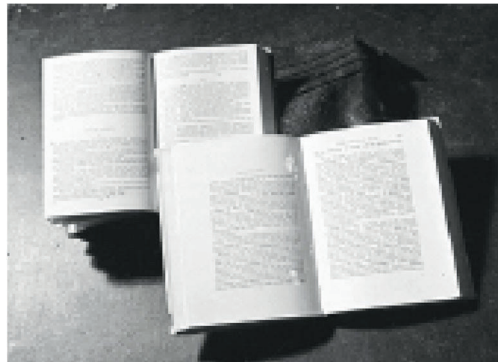

Mark Twain has inspired many people. He is seen as a great American author.



**Item 1**

Directions for TA that this is a two-part item.

TTS or TA reads item directions.

*This is the first item of a two-part item.*

We read about a writer named Mark Twain. We are going to read part of the text again. Then you will be asked a question. Listen for details that tell you that Mark Twain liked to travel.

*[For students with visual impairment, read "This is a picture of a sailboat."]*

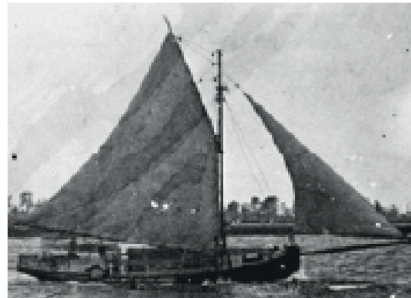

TTS or TA reads item text.

TA reads the alternative text for students with visual impairment to describe the picture.

Twain traveled to many places. He visited libraries around the world. Twain became famous.

TTS or TA reads question text.

Which sentence tells that Mark Twain liked to travel?

*Point to each answer option as the Text to Speech (TTS) or Test Administrator (TA) reads each option.*

*[For students with visual impairment, read "A. This is a picture of a pad of paper with a drawing on it."]*

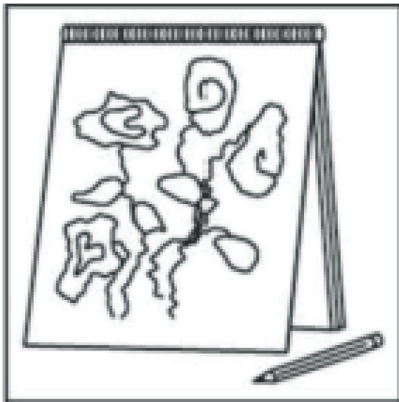

Directions for TA to point to each answer option as the TTS or TA reads each option.

TTS or TA reads answer options.

A. He drew pictures.

[For students with visual impairment, read “B. This is a picture of famous people at a dinner party.”]



B. He became famous.

[For students with visual impairment, read “C. This is a picture of men riding on top of and in a covered wagon pulled by horses.”]



TA asks student if they would like to read this part again. If the student says yes, the TA either activates the starting point for the TTS to read the passage part or reads the passage part again.

C. He traveled to many places.

Would you like to read this part again before you answer the question?

### **Constructed-Response Item**

The constructed-response (CR) item requires the student to produce a response to a writing prompt (i.e., expressive language). The item is presented to the student in a standardized, scripted sequence of steps that include statements read by the TTS and TA and directions for the presentation of grade- and prompt-specific materials that need to be prepared as appropriate for each student. The Student Response Template is identified by a card number for each CR item in the Writing Stimuli. The student may use the Student Response Template located in the *ELA Reference Materials and Writing Stimuli* to write a response to the CR item, but **the final product is entered into the DRC INSIGHT Assessment System**. Please note that if the TA makes the determination that a student is capable of entering an online response utilizing a keyboard, the student is not required to use the Student Response Template and may type and edit the response in the response spaces in the DRC INSIGHT Assessment System.

A TA needs to determine the way in which a student will create a constructed response in writing. The student can use the Student Response Template to write a response or

can enter an online response utilizing a keyboard. The following statements are provided to assist TAs in determining whether to allow the student to enter an online response into the DRC INSIGHT Assessment System.

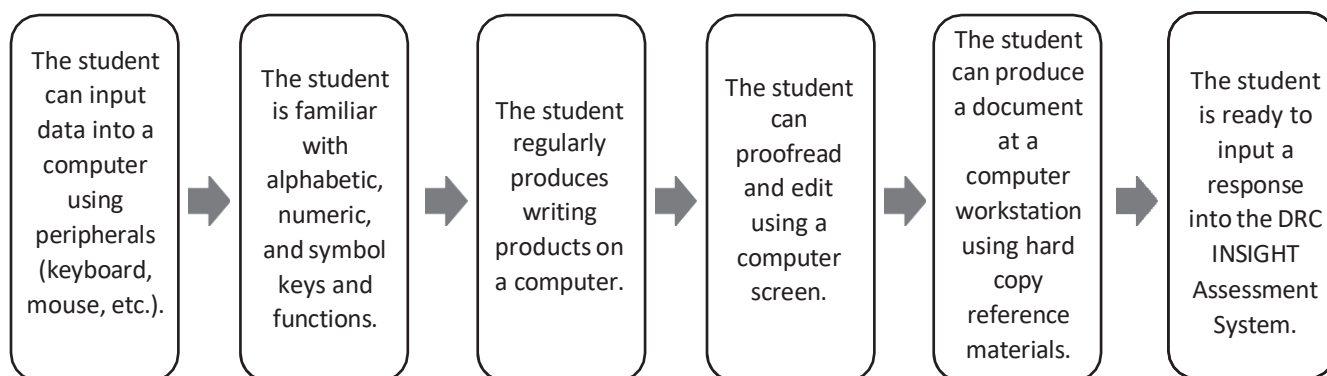

The CR writing prompt is administered in the following manner:

1. The student is presented with the writing task and the text type (e.g., story or essay) to be produced.
2. The student is then presented with a model of the text type.
3. The TA presents the steps of the writing task as planning, writing, revising, and editing a response, using a script that includes references to materials to present to the student to support the construction of a response.
4. First, the student organizes ideas related to the topic. Next, the student writes a response using the provided Student Response Template or types into the DRC INSIGHT Assessment System. Then the student is allowed to revise and edit the response. Last, the TA reads aloud the finished product to the student.
5. If the student types the response into the DRC INSIGHT Assessment System, the student may not utilize the computer's browser functions during CR item administration.
6. If the student did not type the response into the DRC INSIGHT Assessment System, the TA must transcribe the student response into the DRC INSIGHT Assessment System in the appropriate boxes. **The TA must also type any necessary annotations in the text box beneath the item. (See *Procedures for Annotation* and *Procedures for Transcription* below.)**

### ***Procedures for Annotation of Writing CR Item***

To ensure student's written product is easily interpreted during scoring (e.g., use of inventive spelling or symbolic expressions), the TA **must** provide annotations in the DRC INSIGHT Assessment System in the text box beneath the item labeled "*For Test Administrator use if annotations are necessary.*" The annotation is to be written by the TA and must not alter the intent of the student's original response; rather annotation ensures that the response is interpretable and meaningful to a scorer.

After the student has finished composing their written responses, the TA will read the student's response and do the following:

- Add annotation to describe or clarify the intended meaning of pictures, symbols, or objects included in the student's original response.
- Add annotation to clarify incorrect spelling as needed to ensure correct interpretation.
- Make annotations in the proper location (the text box beneath the item) to distinguish from the student's original response.
- If a student types an uninterpretable word (e.g., inventive spelling), type the intended word in parentheses directly following the uninterpretable word in the DRC INSIGHT Assessment System to clarify the student wording. DO NOT remove student wording or phrasing.
- Not include comments or explanations of the student's response except if needed for clarification.
- Provide an opportunity for the student to review and modify what has been annotated.
- The annotation box is **not** intended for TA feedback about the CR item or the LEAP Connect assessments. TAs may send any feedback or questions to [assessment@la.gov](mailto:assessment@la.gov).

### ***Procedures for Transcription of Writing CR Item***

If a student did not type the response into the DRC INSIGHT Assessment System, the TA must transcribe the student's response including any annotations into the response area(s) for that item.

The TA will:

- Enter the response after completing the administration of the CR item.
- Enter the entire response exactly as the student has written it and annotate as appropriate (see *Procedures for Annotation of Writing CR Item*).
- Not revise, edit, or alter the student's response in any way, unless directed to do so by the student.
- Not provide feedback regarding any aspect of the student's response unless directed to do so by the student.

If the student is able to provide a response to the system independently, the TA is encouraged to allow the student to do so. In this case, the TA is not required to complete the task of transcription.

After the TA has transcribed and provided annotations for a constructed-response item, the item is considered completed. When all transcriptions and annotations are completed for the CR item, the session is completed and the test must be submitted.

### ***Use of a Scribe for Writing CR Item***

The TA may decide before testing begins, based on student need, that the use of a scribe is the best way to capture the student's response for the writing CR item. This process should be practiced with the student prior to testing during regular classroom instruction in order to ensure that the student and the TA understand the process. The process of scribing should not be a barrier for the student. If a scribe is utilized, the scribe must: 1) transcribe the work into the online system and 2) annotate. The role of scribe can be completed by either a TA or a district employee under the direction of a qualified, trained TA. For the ELA test only, **an accommodation for scribe or transcription is not required to be included in the student's IEP.**

The scribe will:

- Begin the session with an introduction, explain the process and direct the student to indicate when to use capitalization and punctuation when needed, and must allow the student to revise and edit what the scribe has written.
- Write exactly what the student communicated on paper or directly into the DRC INSIGHT Assessment System.
- Correctly spell all words.
- Capitalize words or punctuate text only when indicated by the student.
- Make student-requested changes, even if incorrect.
- Allow the student to edit for punctuation, capitalization, or other edits as described in the DPTA.
- Orally confirm meaning of homonyms and commonly used homophones (e.g., than and then; to, two, and too; there, their, and they're).

### ***Augmentative and Alternative Communication Guidelines for Writing***

Ensure that AAC and AT that are used routinely for instruction are available to support the student in communicating answer responses. Allow the student to complete the tasks using their preferred method of communication (e.g., pointing, eye gaze, assistive technology, oral response, sign language).

**Please refer to the *LEAP Connect Test Administration Manual, Appendix B*, which provides detailed methods and protocols for using AAC systems and devices to respond to the writing CR items.**

# Session 1

## Directions

We are going to read a text about feeding birds. After we read, you will be asked a question. Listen and look at the picture for what it is about.

### Feeding Birds



Feed the birds outside. Make a bird feeder.

### Find What You Need

*Point to each item as the TTS or TA reads the graphic description.*

*[Graphic description: "You will need a pinecone, string, nut butter, and birdseed."]*

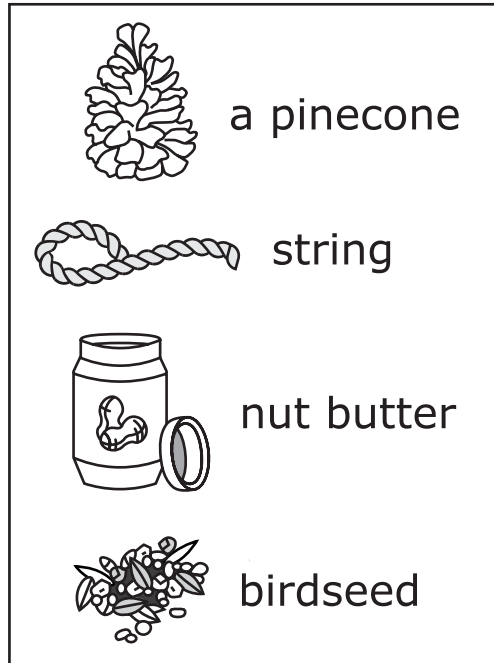

### Make the Bird Feeder



1. Find a pinecone.



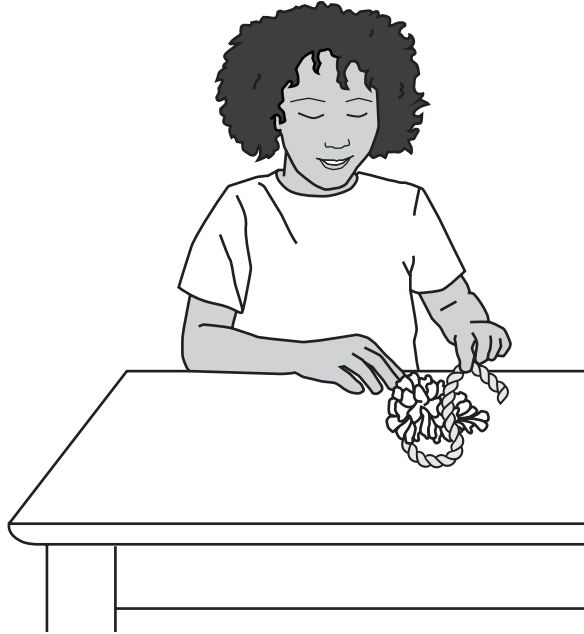

2. Tie a **string** around it.



3. Put nut butter all over it.



4. Roll it in birdseed.

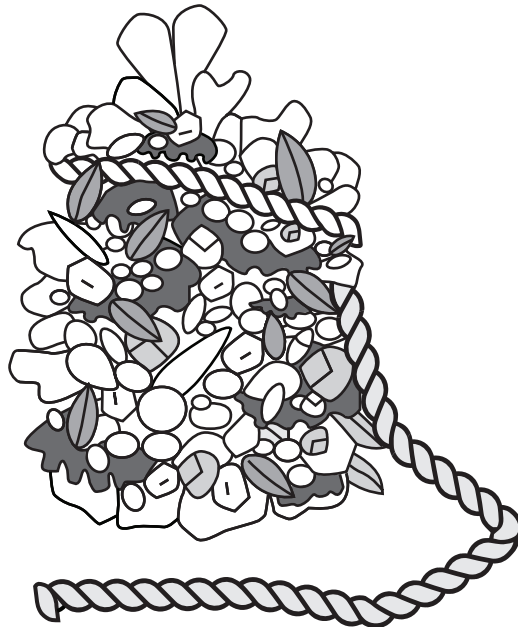

5. Let it dry.



6. Put it in a tree.

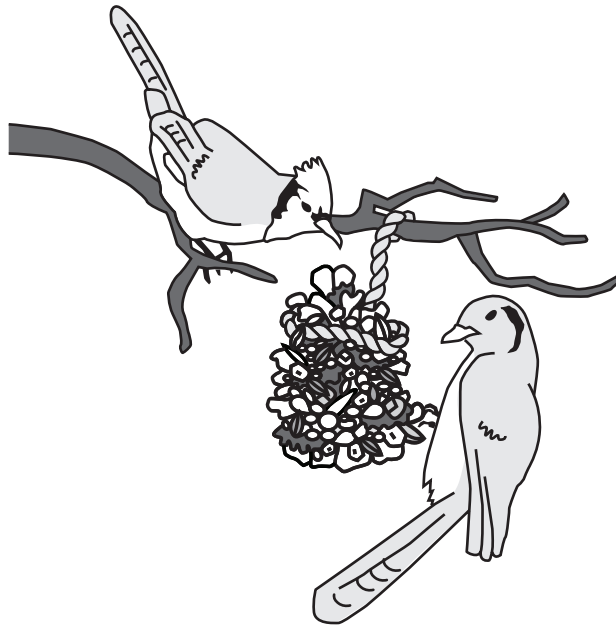

7. Watch the birds eat.

Provide student with Picture 1 of a bird feeder ingredients list from the Grade 3 ELA Reference Materials.

We read about feeding birds. We are going to read part of the text and look at a picture again. Then you will be asked a question. Listen and look at the picture for what it is about.

### Find What You Need

*Point to each item as the TTS or TA reads the graphic description.*

*[Graphic description: "You will need a pinecone, string, nut butter, and birdseed."]*

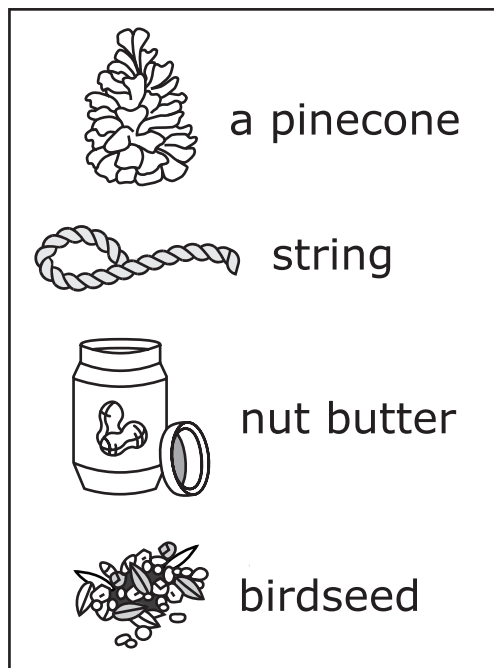

**Item 1**

What is this picture about?

*Point to each option as the TTS or TA reads each option.*

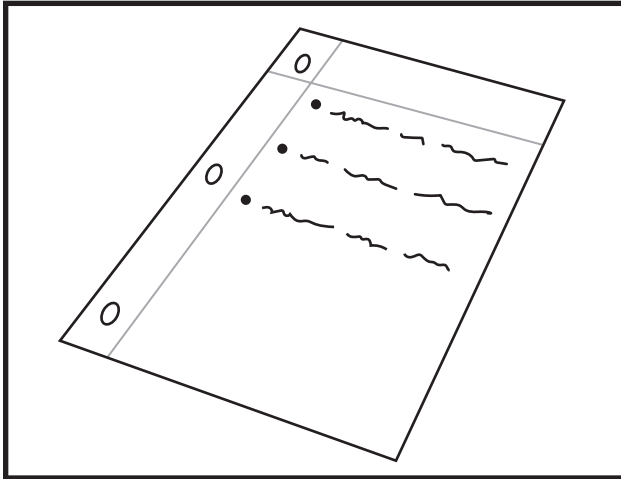

A. a list of things you need to have

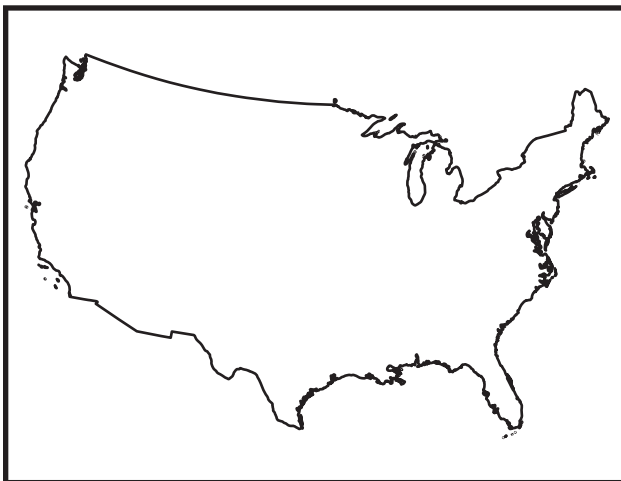

B. a map of where you need to travel

Would you like to read this part and look at the picture again before you answer the question?

## Item 2

We read about feeding birds. We are going to read part of the text again. Then you will be asked a question about a text feature.

### Make the Bird Feeder



1. Find a pinecone.



2. Tie a **string** around it.



3. Put nut butter all over it.

Remember, text features give more information about the topic.

Which text feature is **Make the Bird Feeder**?

*Point to each option as the TTS or TA reads each option.*

- A. a caption
- B. a heading

Would you like to read this part again before you answer the question?



### Item 3

We read about feeding birds. We are going to read part of the text and look at some pictures again. Then you will be asked a question. Listen and look at the pictures of the steps to make a bird feeder.



4. Roll it in birdseed.

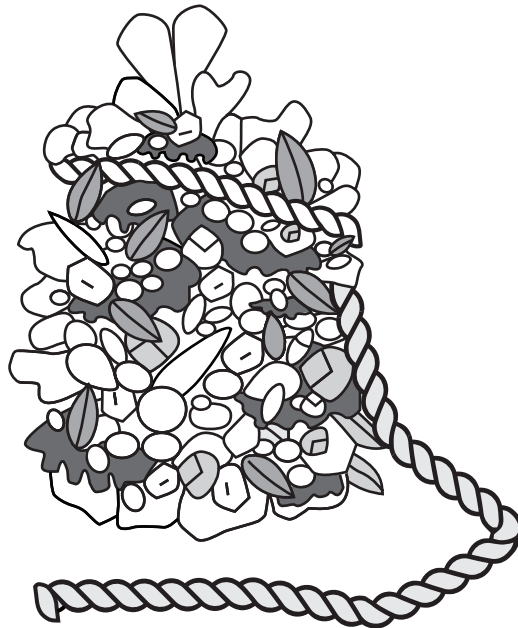

5. Let it dry.



6. Put it in a tree.

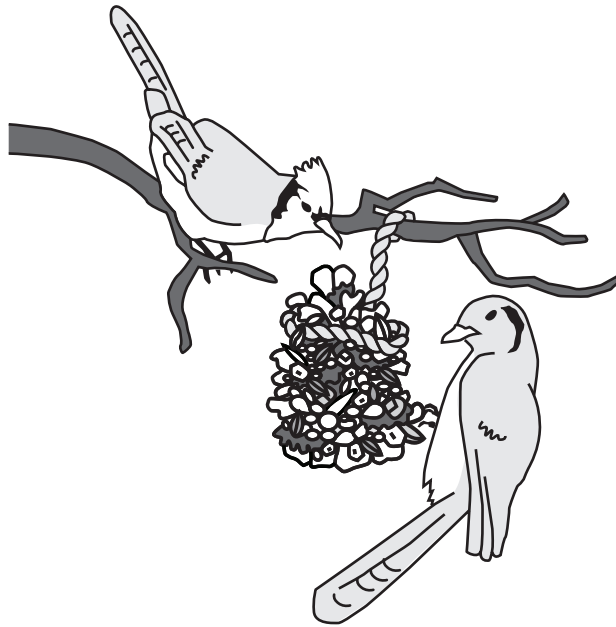

7. Watch the birds eat.

Which picture shows where the bird feeder goes once it is dry?

*Point to each option as the TTS or TA reads each option.*

*[For students with visual impairment, read "A. This is a picture of a truck."]*

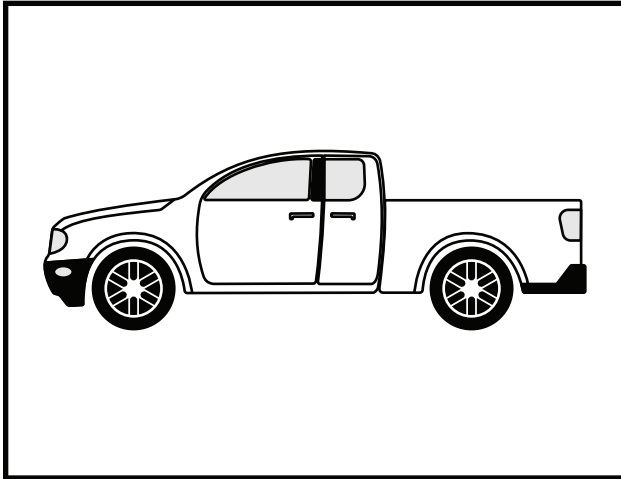

A.

*[For students with visual impairment, read "B. This is a picture of a tree."]*

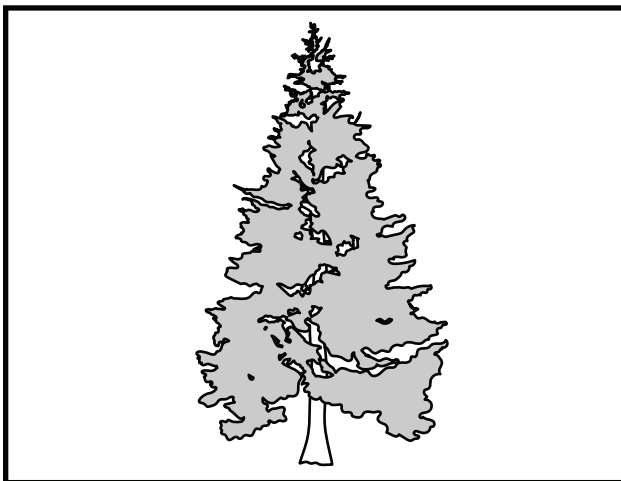

B.

Would you like to read this part and look at the pictures again before you answer the question?

#### Item 4

We read about feeding birds. We are going to read part of the text again. Listen for clues that tell you what the word **string** means.

#### Make the Bird Feeder



1. Find a pinecone.

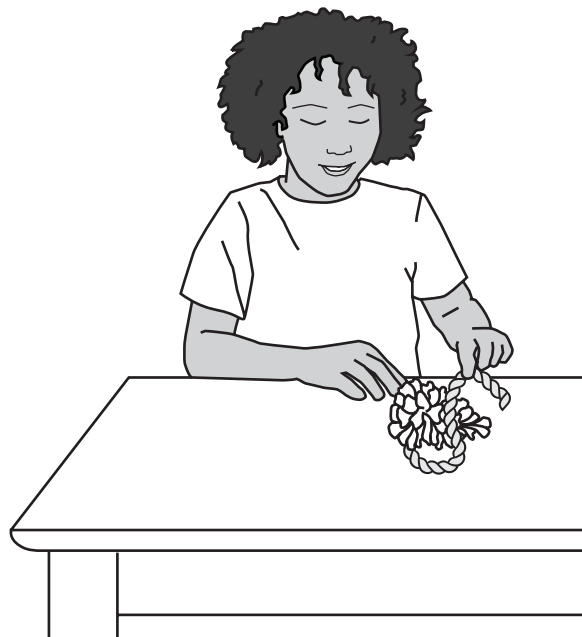

2. Tie a **string** around it.



3. Put nut butter all over it.

*Point to the bolded word.*

What does the word **string** mean in this sentence?

*Point to each option as the TTS or TA reads each option.*

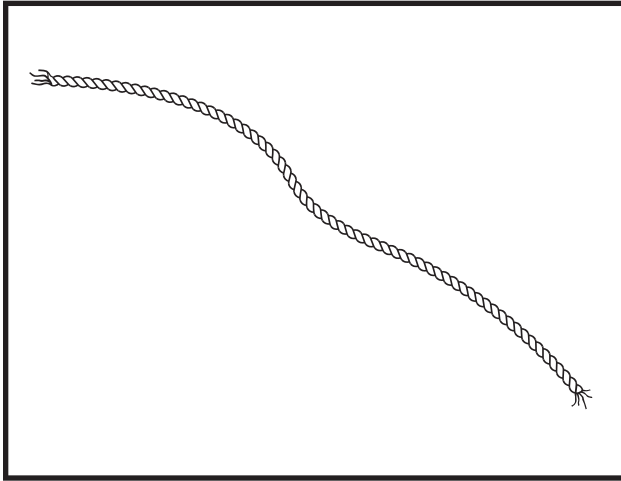

A. a thin cord

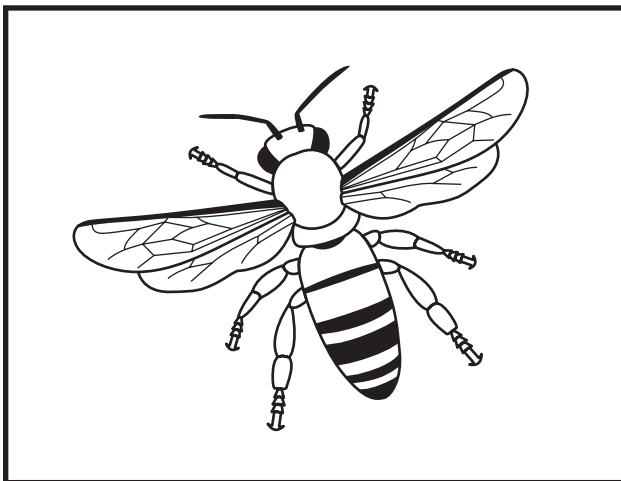

B. a kind of bee

Would you like to read this part again before you answer the question?

## Directions

We are going to read a story about a girl who has a lot of toys. After we read, you will be asked a question about the central message.

### The Gift of Giving

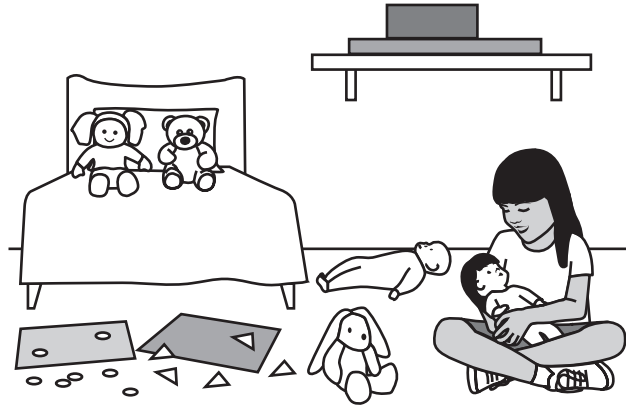

Camila loves her toys. She has lots of dolls and stuffed animals. There are games on the shelf and the floor. She has so many toys. She cannot play with all of them.

Camila's mom sees toys everywhere in Camila's room. There are dolls on the floor. There are stuffed animals on the bed. There are game pieces all over the floor.

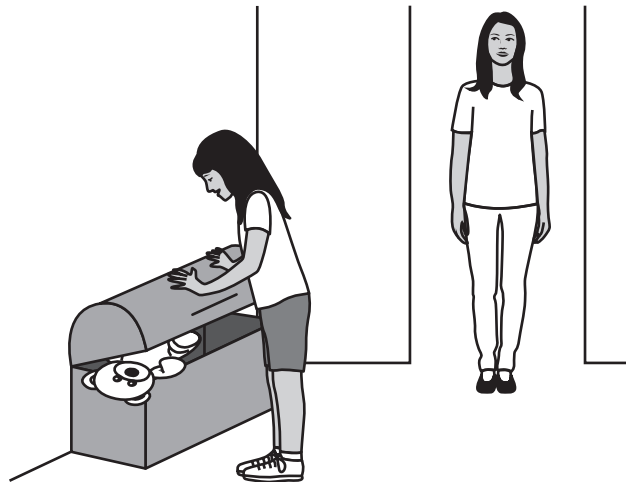

Camila's mom tells her to put the toys away. Camila tries to put them away. But there is not enough room for everything. The shelf is not big enough for all the games. There are too many stuffed animals in her toy **chest**. The lid will not close because it is too full. There is nowhere to put her dolls. Camila's mom tells her to give some of the toys away. But Camila does not want to.

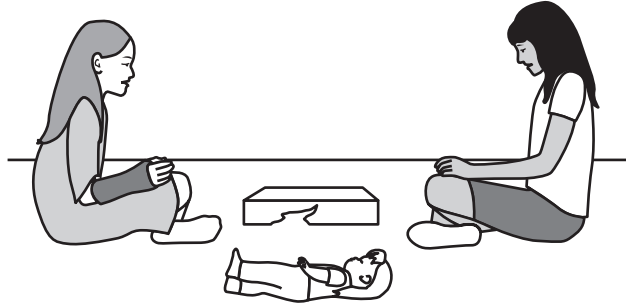

Her mom has an idea. She takes Camila to visit the children’s hospital. Camila meets a girl in the playroom. The girls want to play together. They cannot play a game because pieces are missing. There is only one doll. There are no stuffed animals. Camila notices that the playroom does not have many toys. It makes her sad.

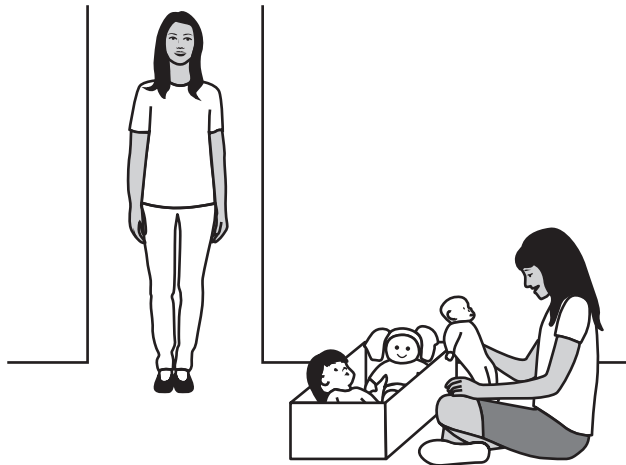

Camila makes a plan when she gets home. She puts some games in a box. She fills the box with dolls and stuffed animals. Camila tells her mom she wants to give the box of toys away. They take the toys to the children’s hospital. Camila feels good that she can share her toys. She hopes the children enjoy the toys, too!



**Item 5**

Remember, the central message is an important idea in the story.

What is a central message in this story?

*Point to each option as the TTS or TA reads each option.*

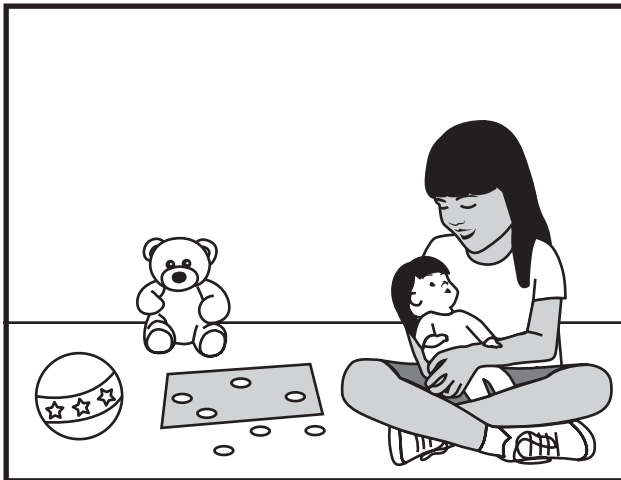

A. There are many kinds of toys.

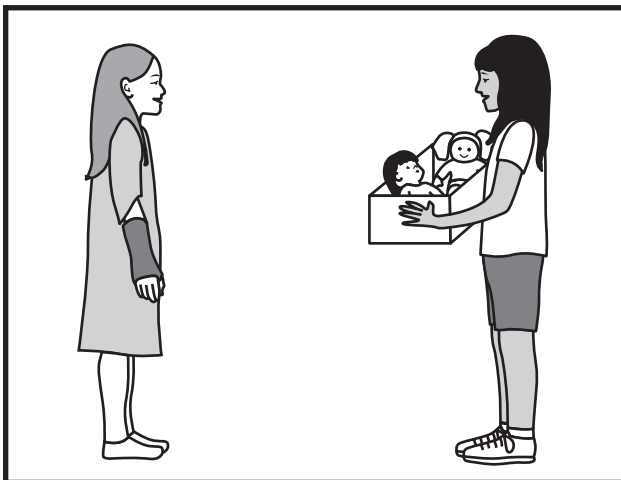

B. Sharing with others feels good.

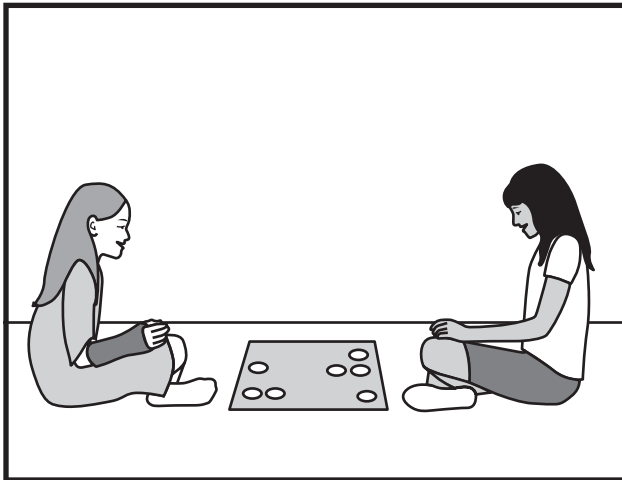

C. Girls like to play games together.

Would you like to read the story again before you answer the question?

## Item 6

We read a story about Camila who has a lot of toys. We are going to read part of the story again. Then you will be asked a question about a problem Camila has with her toys.

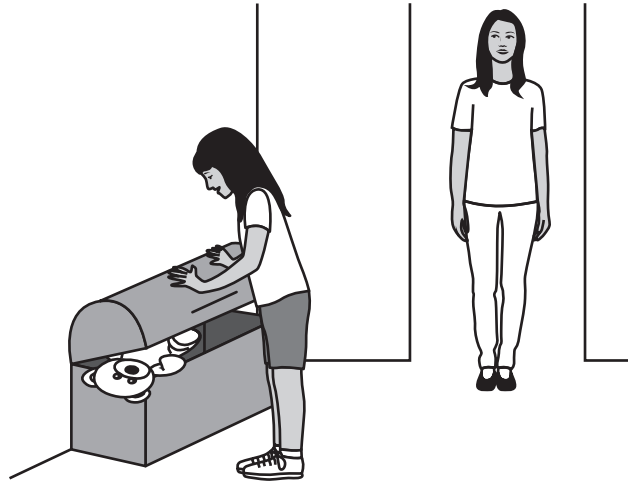

Camila's mom tells her to put the toys away. Camila tries to put them away. But there is not enough room for everything. The shelf is not big enough for all the games. There are too many stuffed animals in her toy **chest**. The lid will not close because it is too full. There is nowhere to put her dolls. Camila's mom tells her to give some of the toys away. But Camila does not want to.

What problem does Camila have with her toys?

*Point to each option as the TTS or TA reads each option.*

- A. She does not have enough room to put them away.
- B. She does not like the games and stuffed animals she has.
- C. She does not want her mom to help her clean up her room.

Would you like to read this part again before you answer the question?

### Item 7

We read a story about Camila who has a lot of toys. We are going to read part of the story again. Then you will be asked a question about a problem the girls have when they try to play a game.

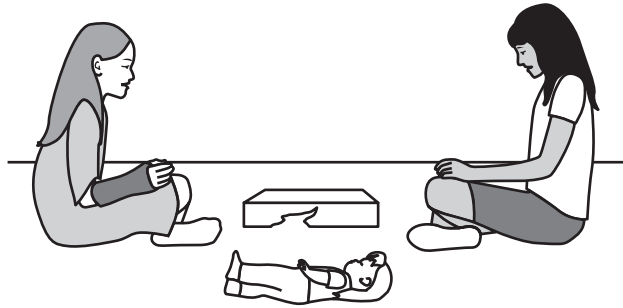

Her mom has an idea. She takes Camila to visit the children's hospital. Camila meets a girl in the playroom. The girls want to play together. They cannot play a game because pieces are missing. There is only one doll. There are no stuffed animals. Camila notices that the playroom does not have many toys. It makes her sad.

What problem do the girls have when they try to play a game?

*Point to each option as the TTS or TA reads each option.*

- A. They just met.
- B. They are only visiting.
- C. The pieces are missing.

Would you like to read this part again before you answer the question?

**Item 8**

What makes Camila sad?

*Point to each option as the TTS or TA reads each option.*

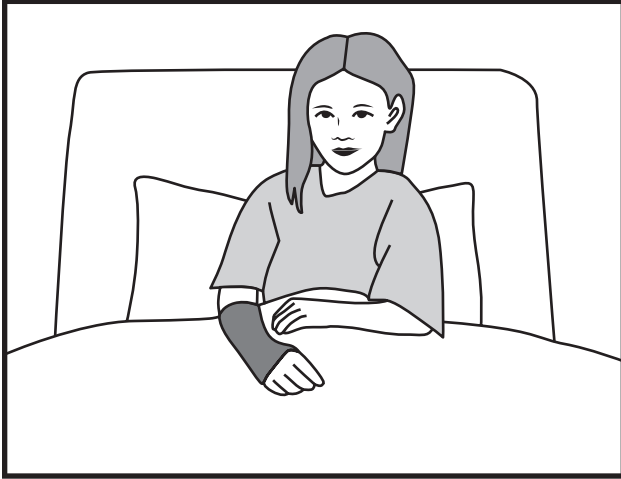

A. The girl in the playroom is staying at the hospital.

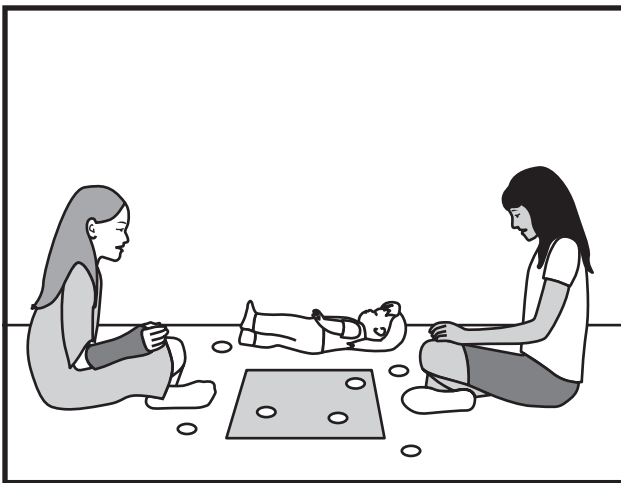

B. There are hardly any toys for the girls to play with.

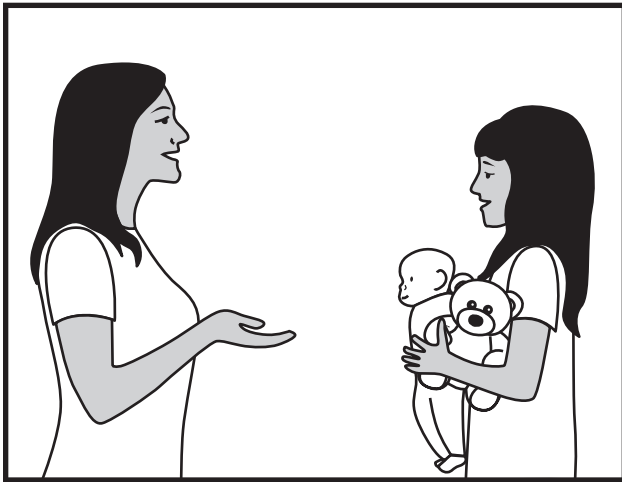

C. Her mom has an idea to help her find space for her toys.

Would you like to read this part again before you answer the question?



### Item 9

We read a story about Camila who has a lot of toys. We are going to read part of the story again. Then you will be asked a question about why Camila puts her toys in a box.

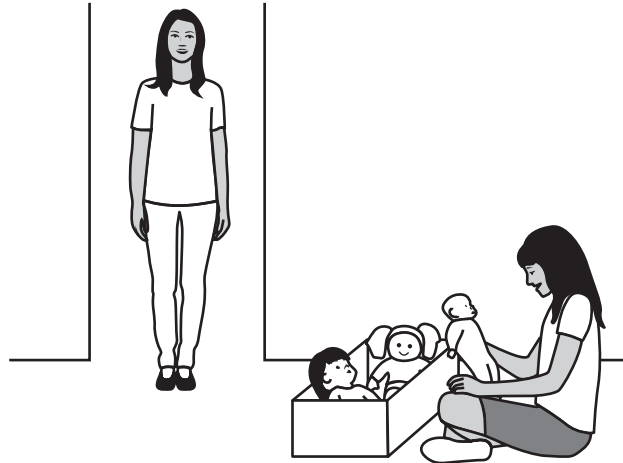

Camila makes a plan when she gets home. She puts some games in a box. She fills the box with dolls and stuffed animals. Camila tells her mom she wants to give the box of toys away. They take the toys to the children's hospital. Camila feels good that she can share her toys. She hopes the children enjoy the toys, too!

Why does Camila put her toys in a box?

*Point to each option as the TTS or TA reads each option.*

- A. to have a place for her games
- B. to make room for more toys
- C. to give to the children's hospital

Would you like to read this part again before you answer the question?

**Item 10**

We read a story about a girl who has a lot of toys. We are going to read some sentences again. Listen for clues that tell you what the word **chest** means.

There are too many stuffed animals in her toy **chest**. The lid will not close because it is too full. There is nowhere to put her dolls.

*Point to the bolded word.*

What does the word **chest** mean in this sentence?

*Point to each option as the TTS or TA reads each option.*

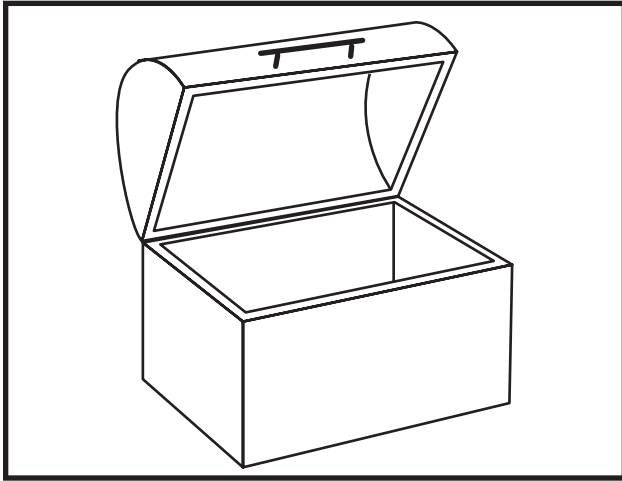

A. a place to keep things

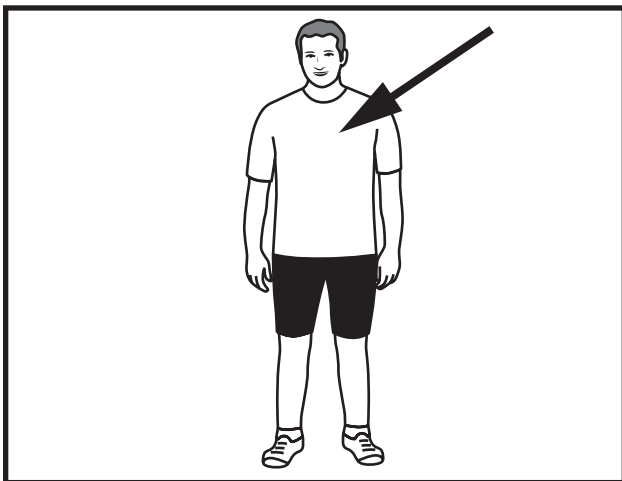

B. a part of the body

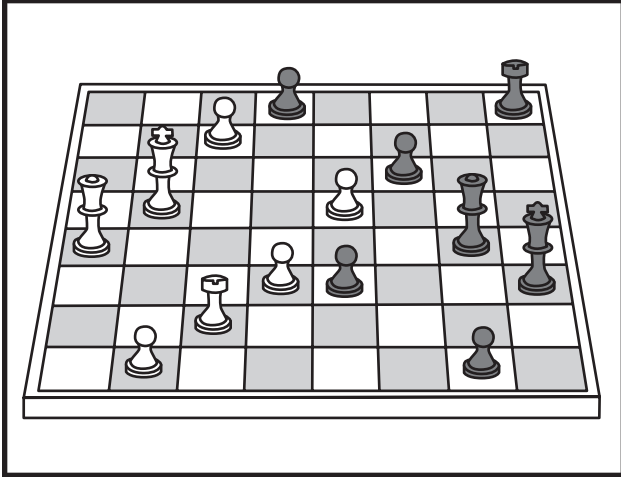

C. a gameboard

Would you like to read the sentences again before you answer the question?

## Directions

We are going to read an informational text titled, “A Playground for All.” After we read, you will be asked some questions. The first question will be about the main idea. Listen for an important idea of the text.

### A Playground for All

*Point to the playground diagram as the TTS or TA reads the graphic description.*

*[Graphic description: “This is a picture of a playground. There is a swing, a double slide, and some chairs.”]*

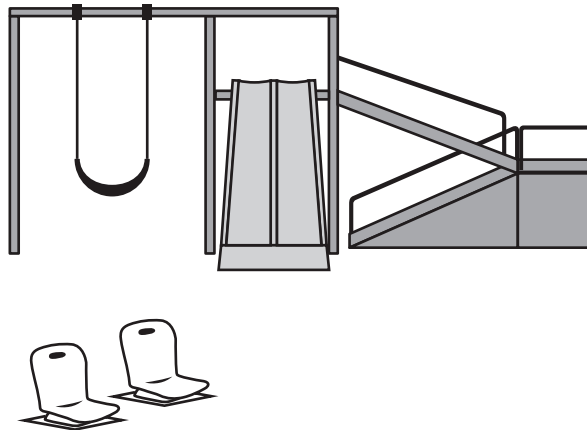

Playgrounds are fun. But they are not all the same. There are different kinds of playgrounds. This playground is special. It is for all children. Everyone can use it.

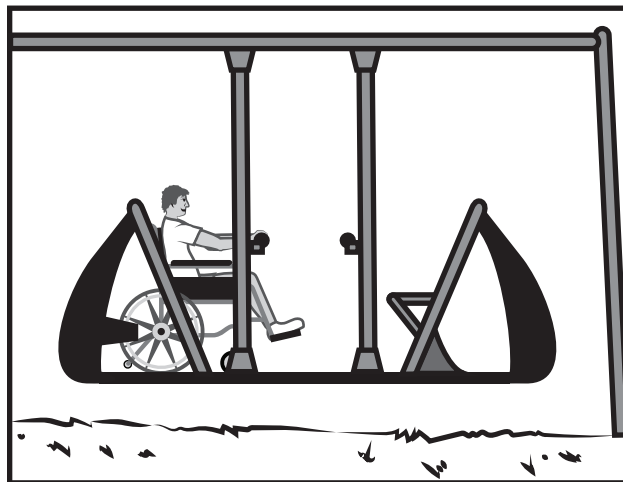

## Swings

The playground has different things so all children can play. There are swings with two sides. Children in wheelchairs can play on these swings. A friend can swing on the other side. They use their arms to move the swing.

*Point to the diagram as the TTS or TA reads the graphic description.*

*[Graphic description: "This a series of three drawings that shows how to use the wheelchair swing. It is titled, 'Using the Wheelchair Swing.' The first picture is of a person in a wheelchair that is parked in the swing. Below, it says, Park the wheelchair. The second picture is of a person in a wheelchair pulling down the bars. Below, it says, Pull down the bars. The third picture is of a person in a wheelchair. Their hands are on the bars and they are smiling. Below, it says, Hold on and have fun!"]*

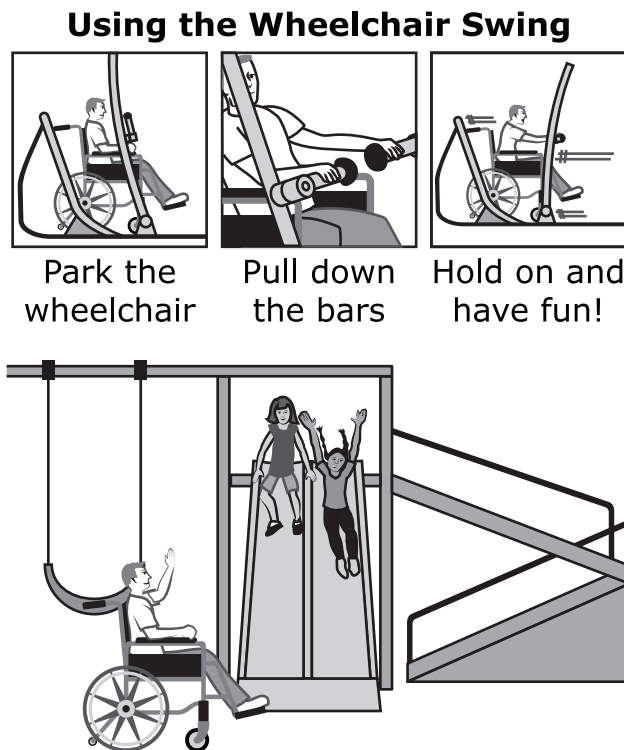

## The Slide

There is a slide. It has two slides next to each other. Two children can share the slide and go down together. Or they take turns. Children in wheelchairs can wait at the end. They can give all their friends a high five.



### **Quiet Time**

Not all children like to play. Some children like to be alone. These chairs rock back and forth. The chairs are good places to sit and be quiet.

### **All Children**

This playground has games for all children. There is something for everyone to enjoy at this playground.



**Item 11**

*This is the first item of a two-part item. Student may not return to this item after responding to the item.*

Remember, the main idea is an important idea of the text.

What is the main idea of this text?

*Point to each option as the TTS or TA reads each option.*



A. a wheelchair

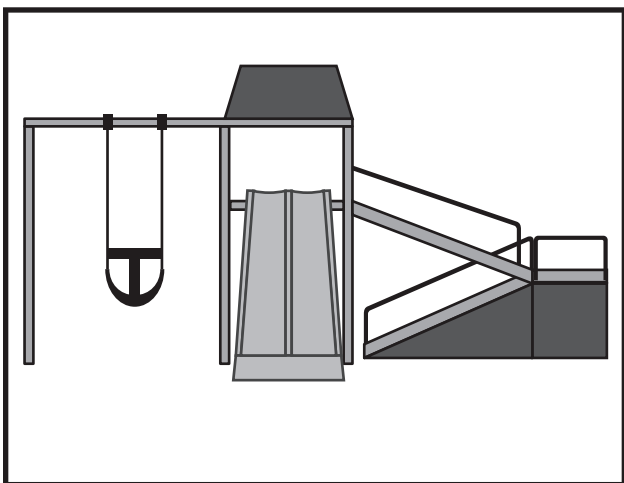

B. a special playground



C. a birthday party

Would you like to read the text again before you answer the question?

*This is the first item of a two-part item. Student may not return to this item after responding to the item.*

**Item 12**

*This is the second item of a two-part item. Student may not return to the previous item.*

The main idea of this text is about a special playground.

Which sentence tells about a special playground?

*Point to each option as the TTS or TA reads each option.*

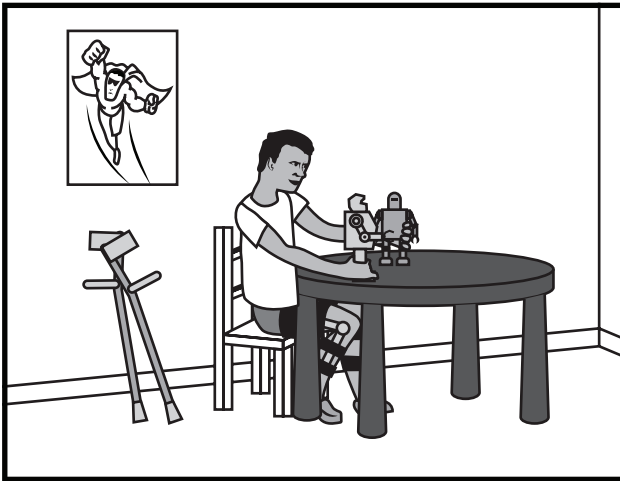

A. "They can play with their friends."

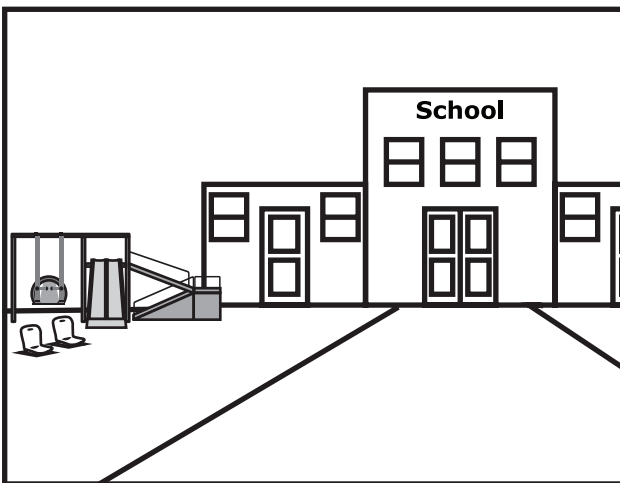

B. "My school has a playground."

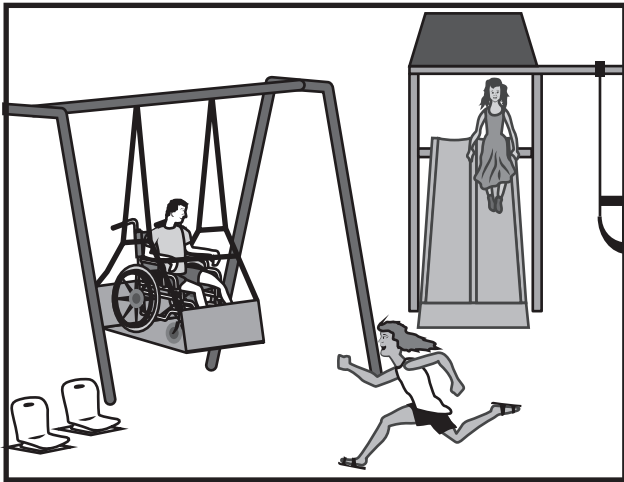

C. “The playground has different things so all children can play.”

Would you like to read the text again before you answer the question?

### Item 13

We read about a special playground. We are going to read part of the text and look at a picture again. Then you will be asked a question. Listen to the text and look at the picture for how the children move the swing.

*Point to the picture as the TTS or TA reads the passage part.*

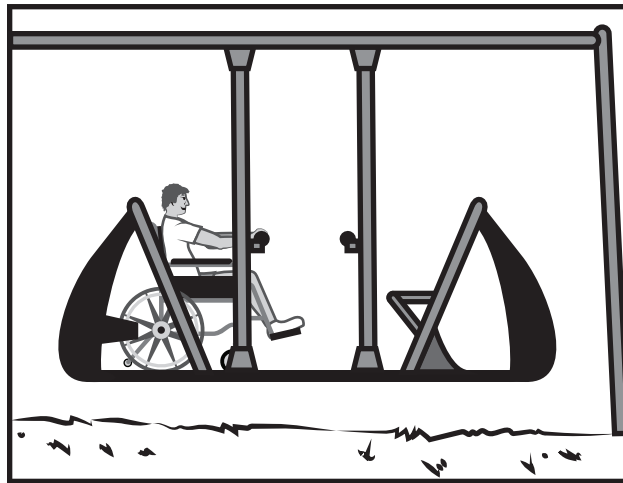

### Swings

The playground has different things so all children can play. There are swings with two sides. Children in wheelchairs can play on these swings. A friend can swing on the other side. They use their arms to move the swing.

How do the children move the swing?

*Point to each option as the TTS or TA reads each option.*



A. with a rope

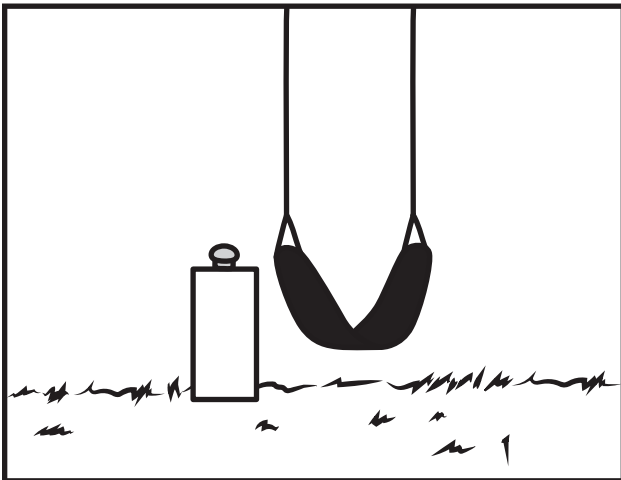

B. with a button

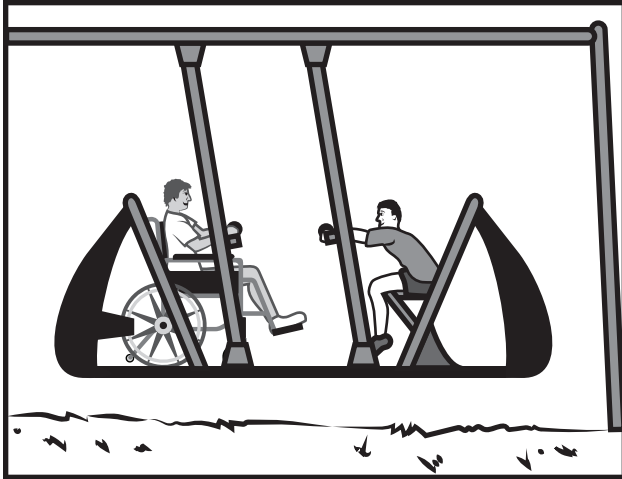

C. with their arms

Would you like to read this part and look at the picture again before you answer the question?

**Item 14**

We read about a special playground. We are going to read part of the text again and look at the diagram.

*Point to each picture as the TTS or TA reads the graphic description.*

*[Graphic description: “This is a series of three drawings that shows how to use the wheelchair swing. It is titled, ‘Using the Wheelchair Swing.’ The first picture is of a person in a wheelchair that is parked in the swing. Below, it says, Park the wheelchair. The second picture is of a person in a wheelchair pulling down the bars. Below, it says, Pull down the bars. The third picture is of a person in a wheelchair. Their hands are on the bars and they are smiling. Below, it says, Hold on and have fun!”]*

**Using the Wheelchair Swing**

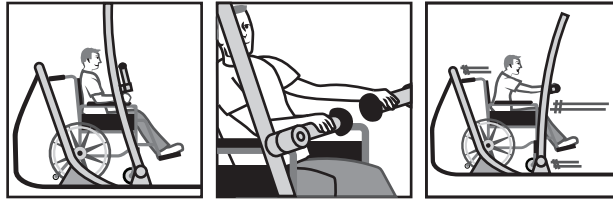

Park the wheelchair

Pull down the bars

Hold on and have fun!



Remember, the main idea is an important idea of the text and pictures.

What is the main idea of this information?

*Point to each option as the TTS or TA reads each option.*



A. How to use a slide.

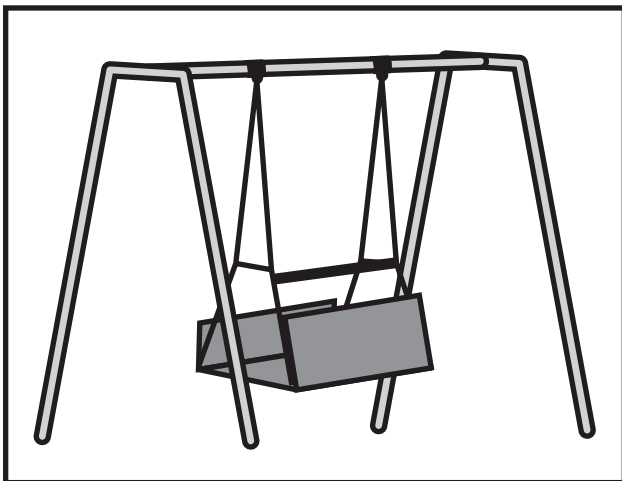

B. How to use a swing for wheelchairs.

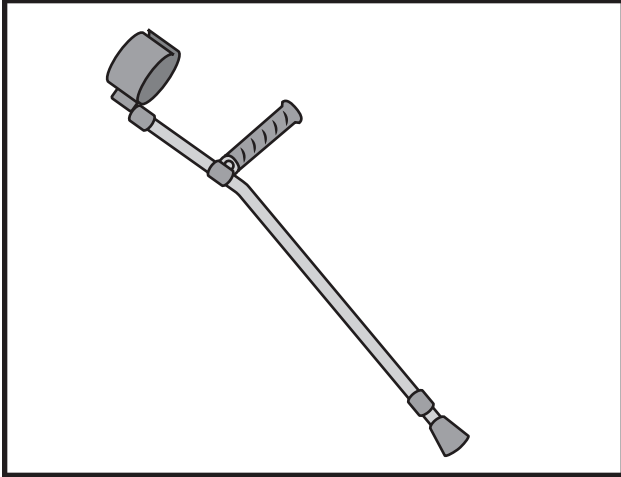

C. How to use a crutch to help someone walk.

Would you like to read and look at the pictures again before you answer the question?

## Item 15

We read about a special playground. We are going to read part of the text again. Then you will be asked a question. Listen to the text and look at what the heading tells you.

*Point to the heading and text as the TTS or TA reads both again.*

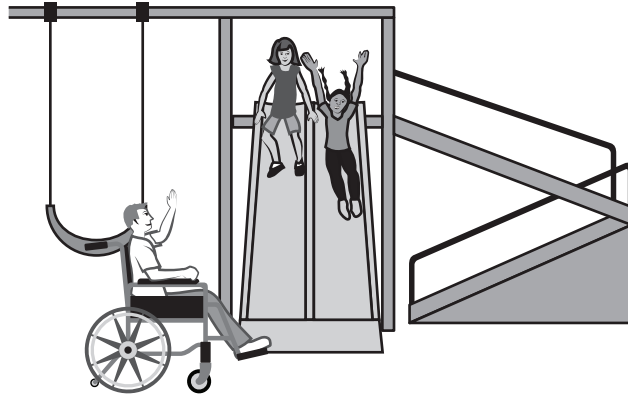

### The Slide

There is a slide. It has two slides next to each other. Two children can share the slide and go down together. Or they take turns. Children in wheelchairs can wait at the end. They can give all their friends a high five.

What does the heading tell you?

*Point to each option as the TTS or TA reads each option.*

- A. how to use the playground
- B. what this part of the text is about
- C. the name of the playground where the children play

Would you like to read this part again before you answer the question?

## Item 16

We read about a special playground. We are going to read part of the text and look at a picture again. Then you will be asked a question. Listen and look for why there is an arrow on the picture.

*[Graphic Description: “This is a picture of 3 chairs at the playground that are round and have space between them. A girl sits in one of them with a thing over her ears. There is an arrow pointing to the thing over her ears. It reads, Headphones. The girl is sitting alone and smiling.]*

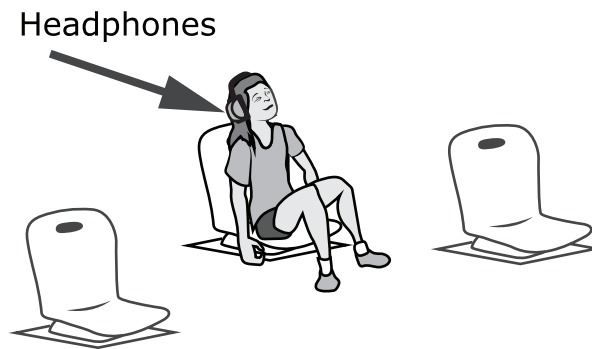

## Quiet Time

Not all children like to play. Some children like to be alone. These chairs rock back and forth. The chairs are good places to sit and be quiet.

Why is there an arrow on the picture?

*Point to each option as the TTS or TA reads each option.*

- A. to show what is on her head
- B. to show the playground
- C. to show the time

Would you like to read this part again before you answer the question?

# You have reached the end of this Session.

## You may choose from the following options:

- Review items in this session
- **Pause** this test and **Resume** later
- Complete this session (**End Test**, then **Submit**) and begin Session 2

# Session 2



## Directions

We are going to read a story about two brothers. After we read, you will be asked some questions about the central idea.

### Working Together for Mom

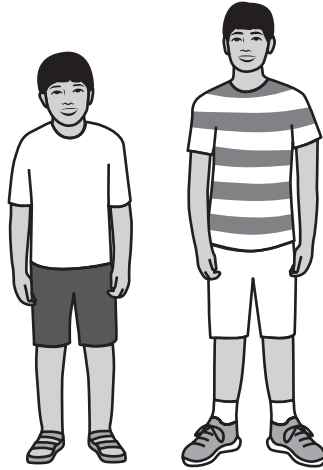

Freddy and Jerry are brothers. Freddy is older than Jerry. They share a room. They have bunk beds. Jerry sleeps on the top bunk, and Freddy sleeps on the bottom bunk.

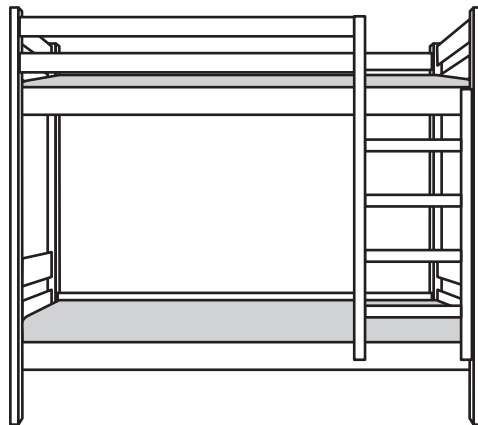

Freddy and Jerry argue all the time. They do not like to share with each other. But Mother's Day is in one week. They want to do something nice for their mom. Their cousin, Leo, tells them they will have to get along to find a good gift for her. Freddy tells Leo, "We have no money." Jerry says, "And Freddy is mean."

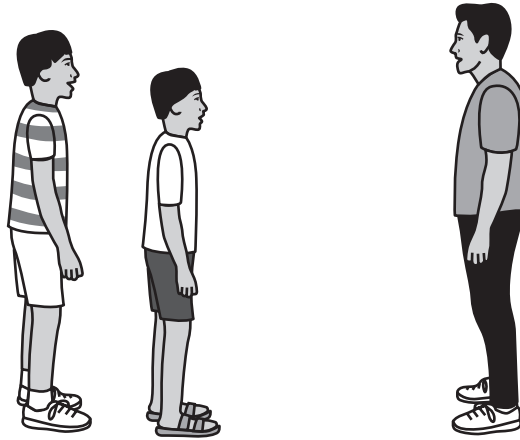

Leo looks around their house and says, “Why don’t you clean up your room for your mom?”

The boys look at each other and smile. Their mom is always asking them to clean their room. This would be a nice surprise for her.

Freddy starts picking up clothes and toys. Jerry climbs up to his bed and lays down. Freddy knows that they will not get their room clean if Jerry does not help.

“Jerry, can you pick up the books and shoes?” Freddy asks nicely.

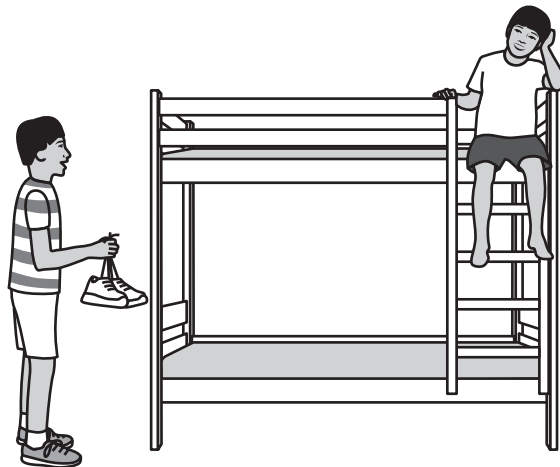

Jerry looks down at him and thinks about it. He knows that the room will not get clean if they do not work together. This time Freddy was not mean. He asked for Jerry’s help in a nice way. Jerry jumps down and begins putting books on the shelf. He slides shoes under the bed. Freddy puts clothes in the laundry basket. They both put their toys away.



Freddy and Jerry do not like to clean their room. But working together has made the **task** easier. Their mom will be so happy when she sees what they did.

**Item 17**

*This is the first item of a two-part item. Student may not return to this item after responding to this item.*

Remember, the central idea is an important idea in the story.

What is a central idea in this story?

*Point to each option as the TTS or TA reads each option.*

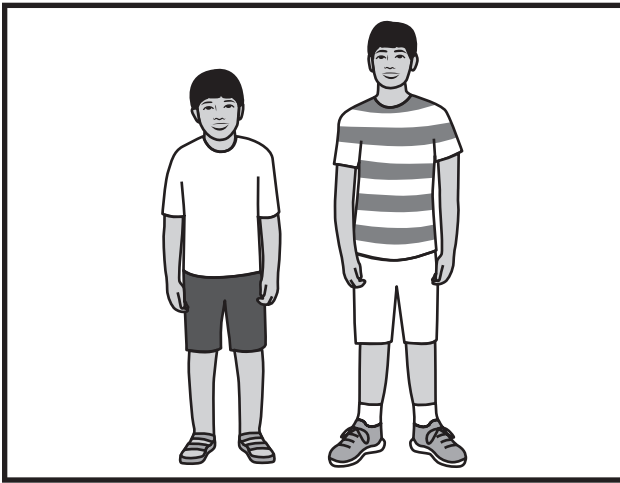

A. Freddy and Jerry are brothers.

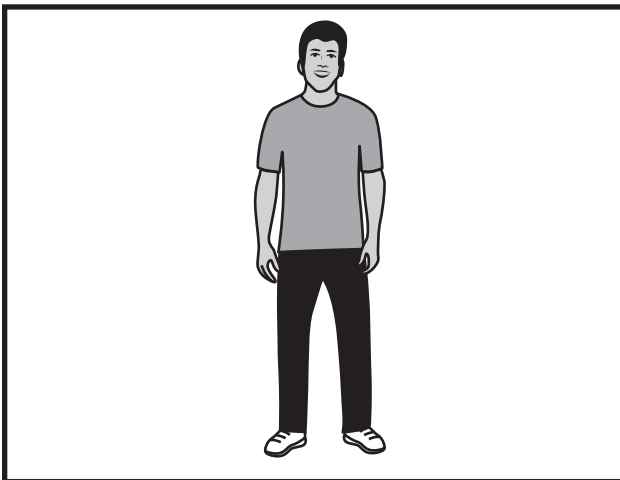

B. Freddy and Jerry have a cousin named Leo.



C. Freddy and Jerry want to do something for their mom.

Would you like to read the story again before you answer the question?

*This is the first item of a two-part item. Student may not return to this item after responding to this item.*

**Item 18**

*This is the second item of a two-part item. Student may not return to the previous item.*

The central idea in this story is that Freddy and Jerry want to do something nice for their mom.

Which sentence supports this central idea?

*Point to each option as the TTS or TA reads each option.*

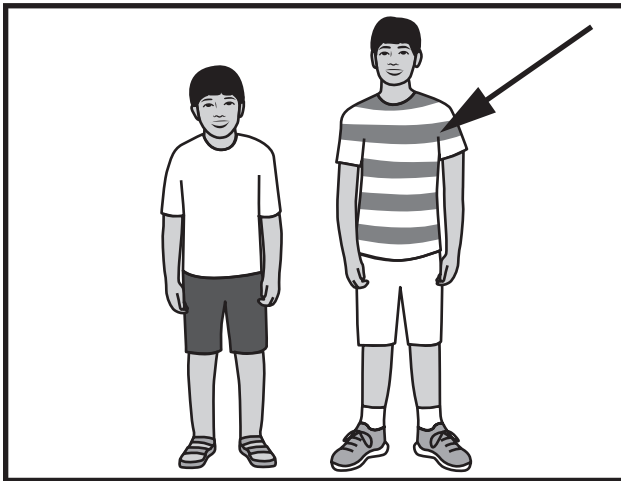

A. Freddy is older than Jerry.



B. Freddy and Jerry clean their room.

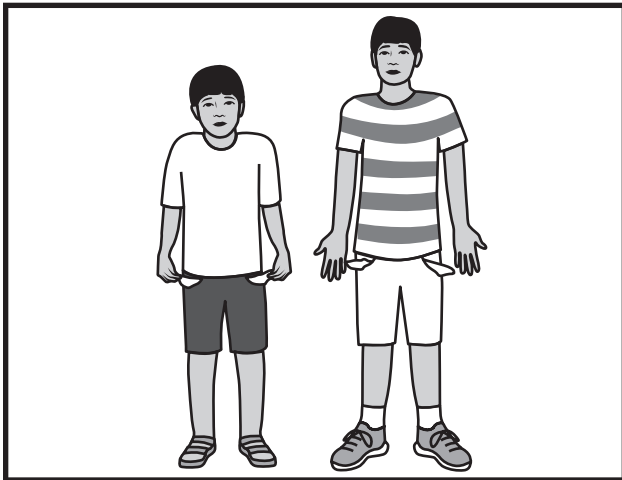

C. Freddy and Jerry have no money for a gift.

Would you like to read the story again before you answer the question?

**Item 19**

Why do Freddy and Jerry clean their room?

*Point to each option as the TTS or TA reads each option.*

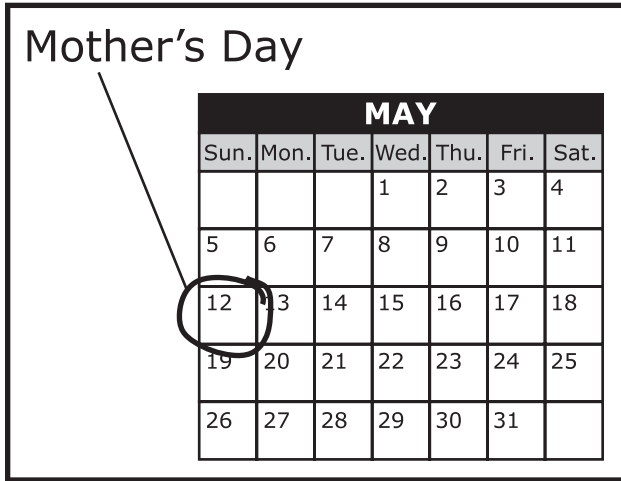

A. As a Mother's Day gift for their mom.

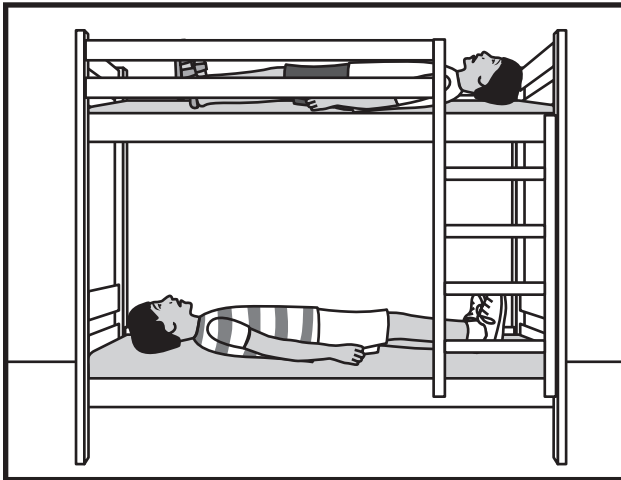

B. They are grounded and cannot play.



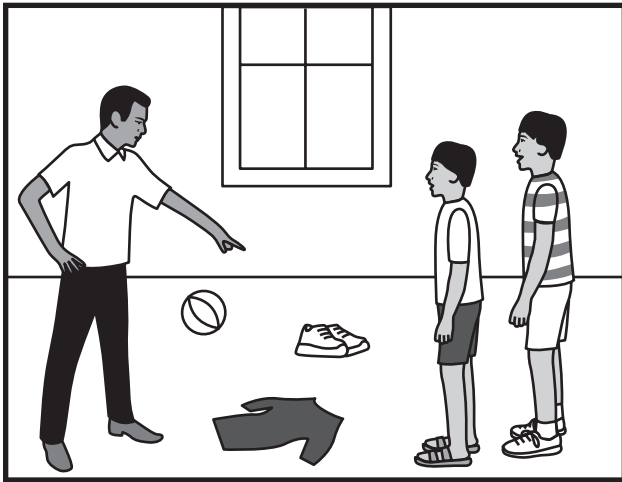

C. Their dad told them to clean their room.

Would you like to read the story again before you answer the question?

**Item 20**

We read about two brothers who work together to do something nice. We are going to read part of the story again. Then you will be asked a question about what they do.

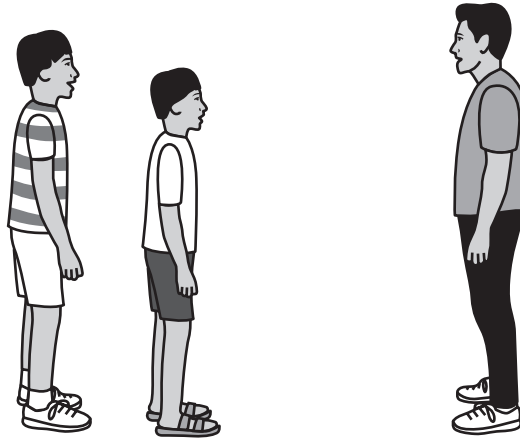

Leo looks around their house and says, “Why don’t you clean up your room for your mom?”

The boys look at each other and smile. Their mom is always asking them to clean their room. This would be a nice surprise for her.

Why do Freddy and Jerry think cleaning their room is a good gift for their mom?

*Point to each option as the TTS or TA reads each option.*

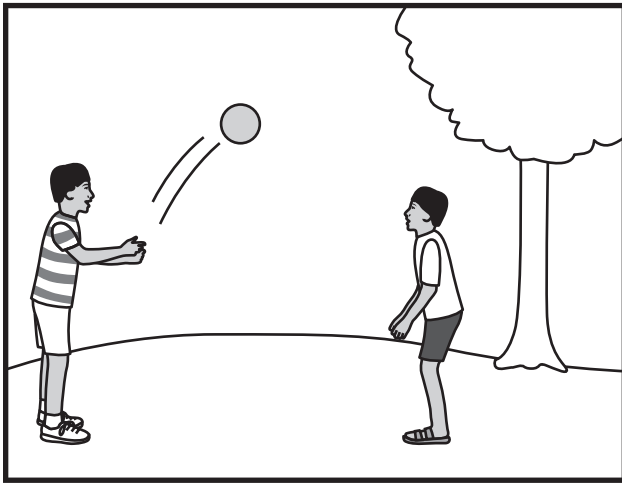

A. They like doing things together.



B. Their mom always asks them to.

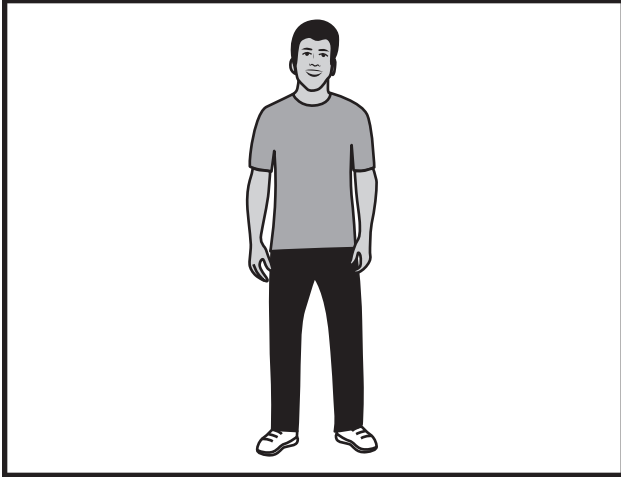

C. Their cousin Leo is their favorite cousin.

Would you like to read this part again before you answer the question?

### Item 21

We read about two brothers who work together to do something nice. We are going to read part of the story again. Then you will be asked a question about what Jerry does to help.

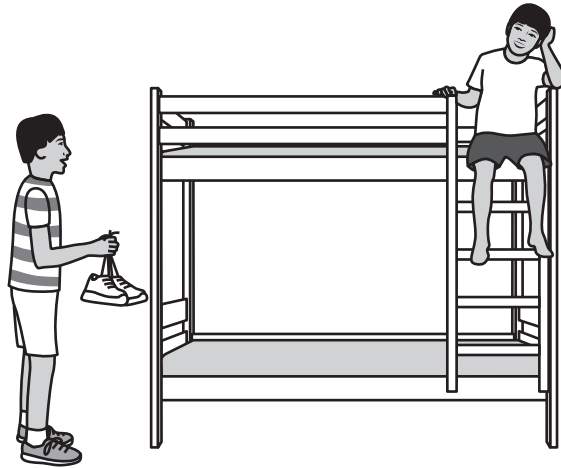

Jerry looks down at him and thinks about it. He knows that the room will not get clean if they do not work together. This time Freddy was not mean. He asked for Jerry's help in a nice way. Jerry jumps down and begins putting books on the shelf. He slides shoes under the bed. Freddy puts clothes in the laundry basket. They both put their toys away.

What does Jerry do to help clean their room?

*Point to each option as the TTS or TA reads each option.*

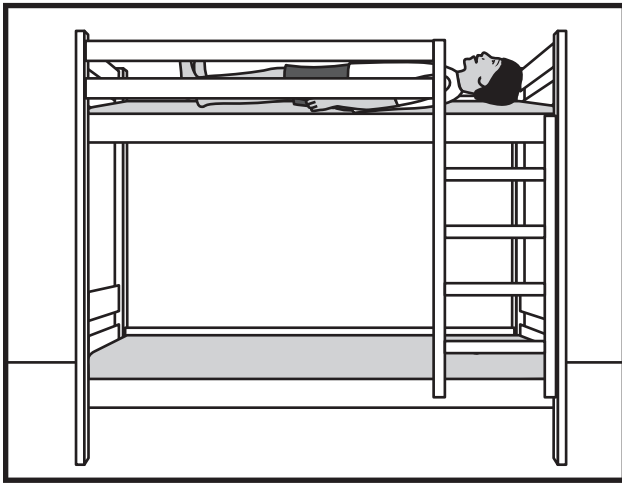

A. He lays on the bed.

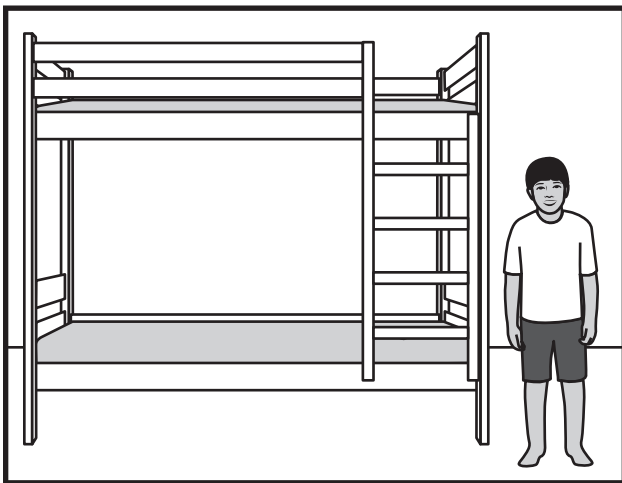

B. He jumps down.



C. He puts away his shoes.

Would you like to read this part again before you answer the question?

**Item 22**

We read about two brothers who work together to do something nice. We are going to read some sentences again. Listen for clues that tell you what the word **task** means.

Freddy and Jerry do not like to clean their room. But working together has made the **task** easier.

*Point to the bolded word.*



What does the word **task** mean in this sentence?

*Point to each option as the TTS or TA reads each option.*

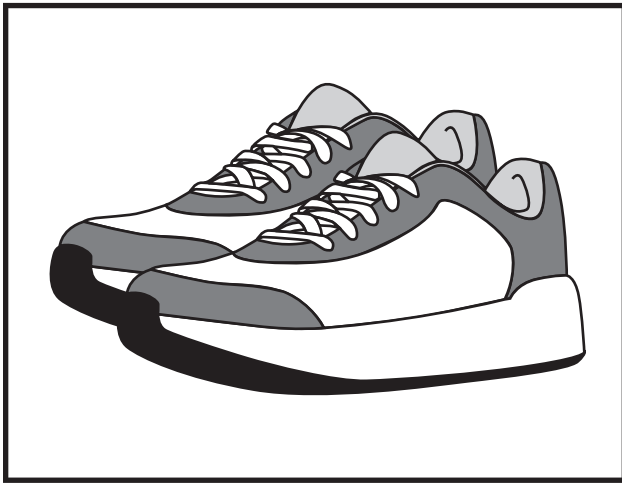

A. A shoe

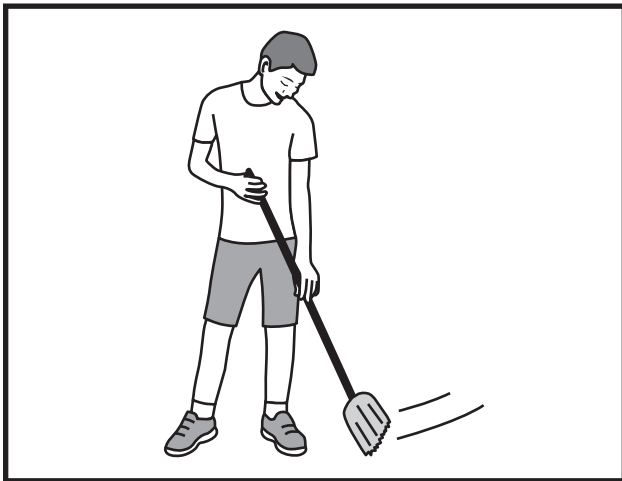

B. A chore

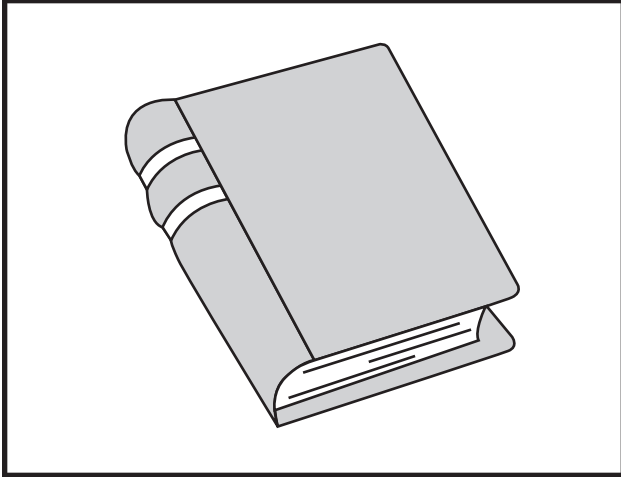

C. A book

Would you like to read this part again before you answer the question?

# You have reached the end of this Session.

## You may choose from the following options:

- Review items in this session
- **Pause** this test and **Resume** later
- Complete this session (**End Test**, then **Submit**) and begin Session 3

# Session 3

**Item 23**

Think about this topic: kinds of clothing.

Which of these is about a kind of clothing?

*Point to each option as the TTS or TA reads each option.*

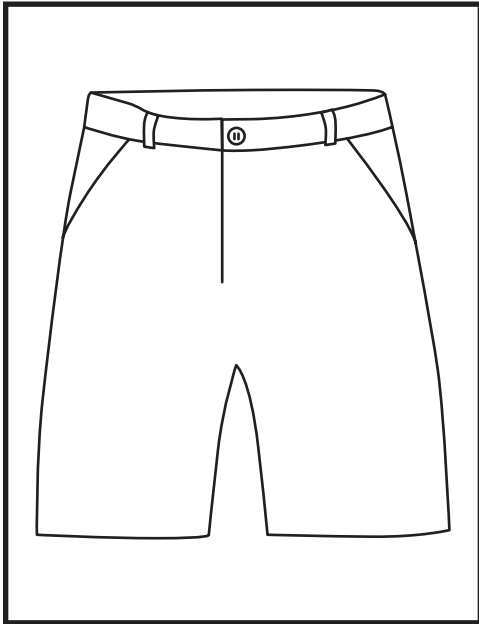

- A. Wear shorts on hot days.

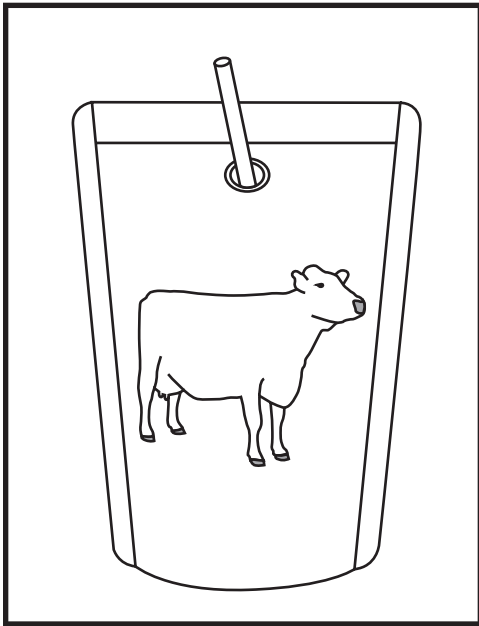

B. Drink milk for lunch.

Would you like to read this again before you answer the question?

**Item 24**

Writers sometimes use pictures.

For example, here is a picture.

*Point to the picture as the TTS or TA reads the graphic description.*

*[Graphic description: "This is a picture of a bird sitting on a tree branch and a squirrel sitting next to a tree trunk."]*

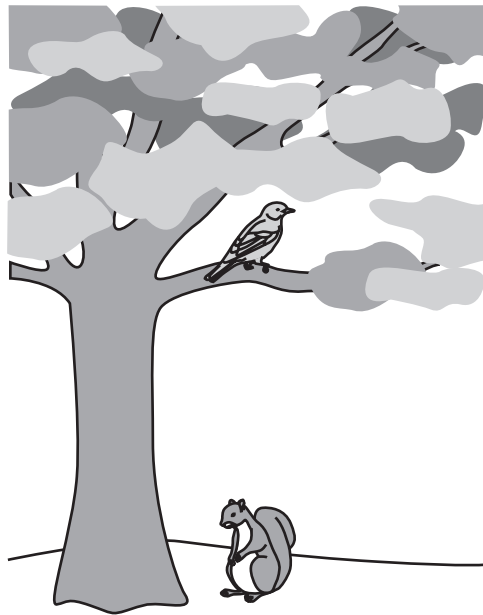

Remember, captions are words that tell what pictures are about.

Which words belong under this picture?

*Point to each option as the TTS or TA reads each option.*

- A. Baseball is a team sport.
- B. Many animals live outside.
- C. Doctors take care of people.

Would you like to read this again before you answer the question?

**Item 25**

Writers sort facts to group information together.

Here are two facts about foods.

*Point to each fact as the TTS or TA reads each fact.*

Apples are fruits.

Carrots are vegetables.

Remember, facts that are alike are grouped together.

Choose the group where the two facts belong.

*Point to each option as the TTS or TA reads each option.*

- A. sizes of food
- B. colors of food
- C. kinds of food

Would you like to read this again before you answer the question?



**Item 26**

Text features give readers more information about a topic.

Remember, text features can include pictures, graphs, charts, or diagrams.

How would a writer best show the different parts of a plant?

*Point to each option as the TTS or TA reads each graphic description.*

*[For students with visual impairment, read "A. This is a drawing of a leaf. It shows what a leaf looks like."]*

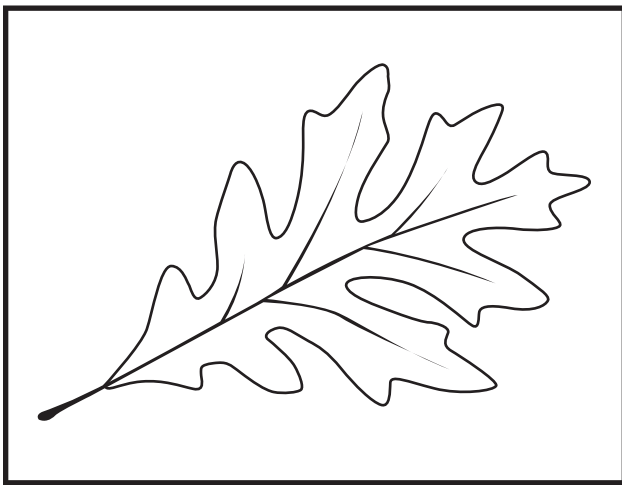

- A. a drawing of a leaf

*[For students with visual impairment, read “B. This is a diagram of a flower with three labels. It has an arrow pointing to a flower petal, labeled flower. It has an arrow pointing to a leaf, labeled leaf. It has an arrow pointing to the stem labeled stem.”]*

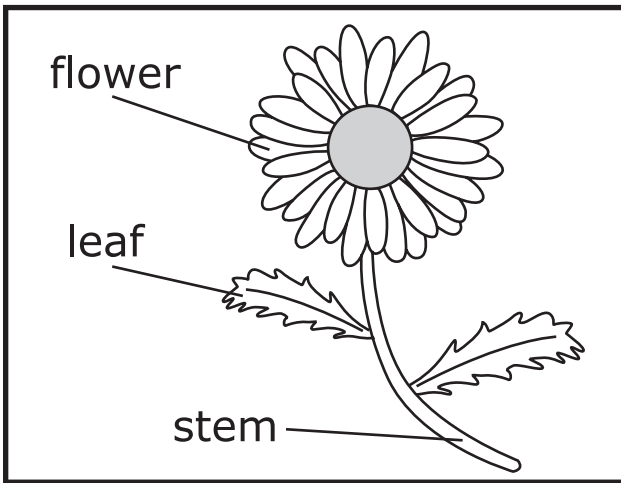

B. a diagram of a flower

*[For students with visual impairment, read “C. This is a graph showing the height of a tree. At the top of the tree there is a mark labeled eighty feet tall.”]*

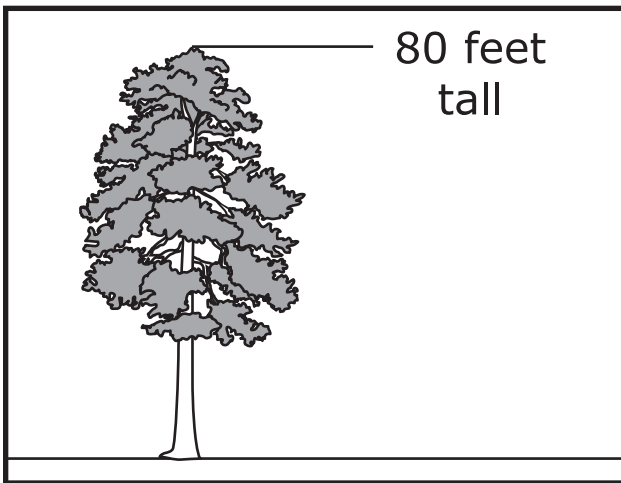

C. a graph of a tree's height

Would you like to read this again before you answer the question?

**Item 27**

*This is the first item of a six-part item. Student may not return to this item after responding to this item.*

*Place Writing Stimulus 1, “A Trip to the Zoo” from the Grade 3 ELA Reference Materials and Writing Stimuli at the side of the student’s workspace. Use a blank sheet of paper to mask the contents.*

You are going to write a story. Your story is about a boy named Noah who goes to a zoo.

First, you will write about the character.

Remember, a character is a person in a story. In this story, the character is Noah.

Which sentence tells about the character, Noah?

*Point to each option as the TTS or TA reads each option.*

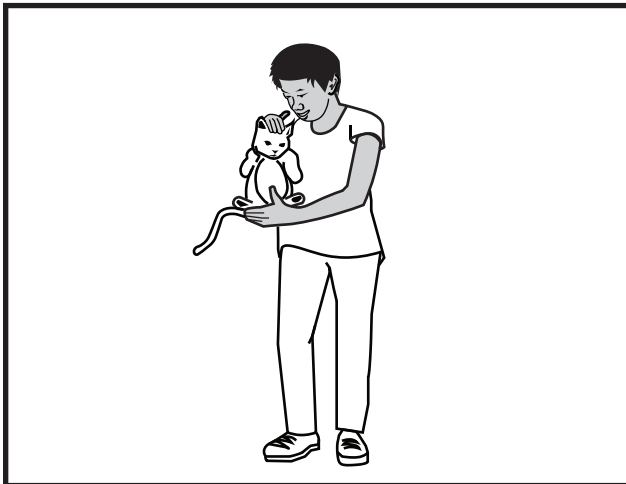

- A. Noah wants to learn about animals.



B. Josh eats breakfast at the kitchen table.

*This is the first item of a six-part item. Student may not return to this item after responding to this item.*

**Item 28**

*This is the second item of a six-part item. Student may not return to the previous item after responding to this item.*

*Point to Writing Stimulus 1, “A Trip to the Zoo” from the Grade 3 ELA Reference Materials and Writing Stimuli. Unmask the first sentence of text as the TTS or TA reads the following statement:*

“Noah wants to learn about animals” tells about the character, Noah.

Next, you will write about the setting. Remember, the setting is where the story happens. In this story, the setting is the zoo.

Which sentence tells about the setting?

*Point to each option as the TTS or TA reads each option.*

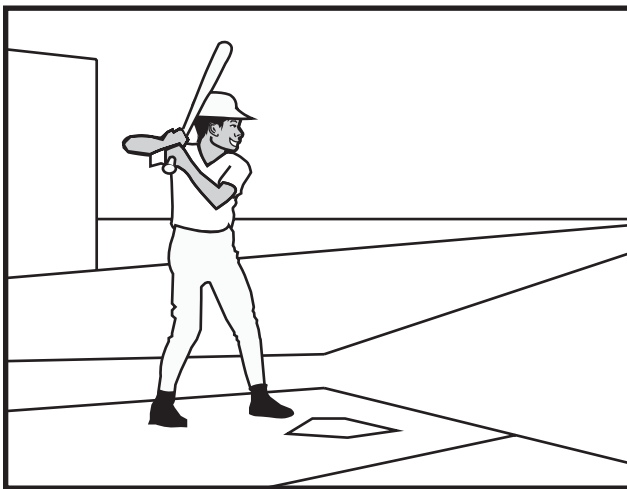

- A. Noah is playing baseball outside.

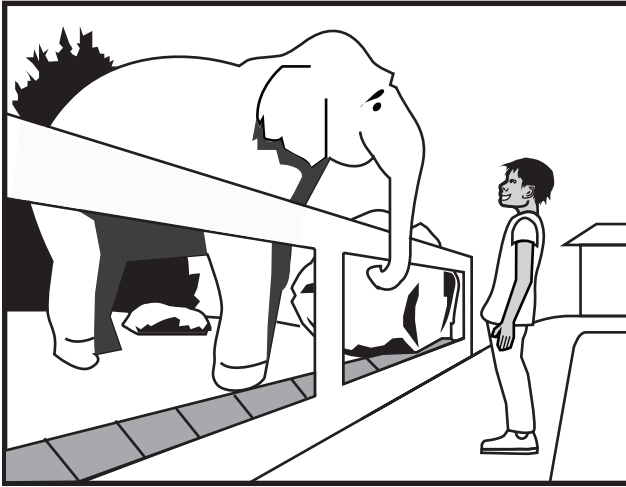

B. Noah is going to the zoo today.

*This is the second item of a six-part item. Student may not return to this item after responding to this item.*

**Item 29**

*This is the third item of a six-part item. Student may not return to the previous item after responding to this item.*

*Point to Writing Stimulus 1, “A Trip to the Zoo” from the Grade 3 ELA Reference Materials and Writing Stimuli. Unmask the second sentence of text as the TTS or TA reads the following statement:*

“Noah is going to the zoo today” tells about the setting, the zoo.

Next, you will write about the first event. Remember, events are things that happen in stories.

Which of these happens first in your story?

*Point to each option as the TTS or TA reads each option.*

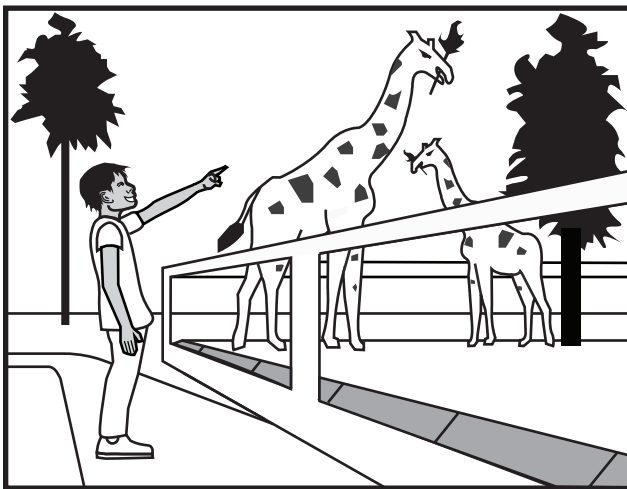

- A. First, Noah visits the giraffes.

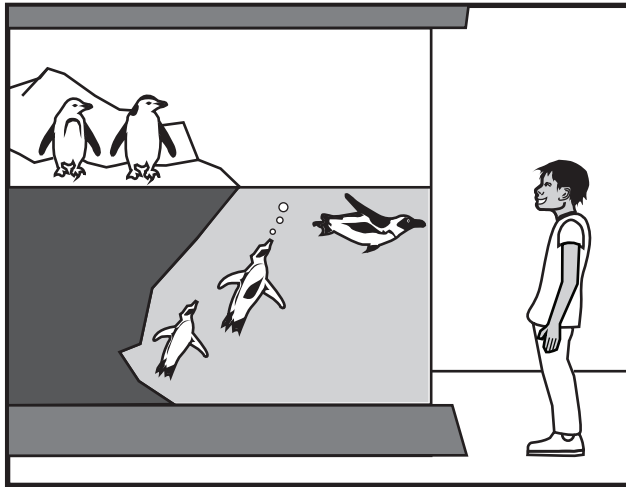

B. Next, Noah watches the penguins.

*This is the third item of a six-part item. Student may not return to this item after responding to this item.*



**Item 30**

*This is the fourth item of a six-part item. Student may not return to the previous item after responding to this item.*

*Point to Writing Stimulus 1, “A Trip to the Zoo” from the Grade 3 ELA Reference Materials and Writing Stimuli. Unmask the third sentence of text as the TTS or TA reads the following statement:*

“First, Noah visits the giraffes” comes first.

*Point to Writing Stimulus 1, “A Trip to the Zoo” from the Grade 3 ELA Reference Materials and Writing Stimuli. Unmask the fourth sentence of text as the TTS or TA reads the following statement:*

“Next, Noah watches the penguins” comes next.

Now tell what the penguins are doing.

Which sentence tells what the penguins are doing?

*Point to each option as the TTS or TA reads each option.*



A. The sun is shining.

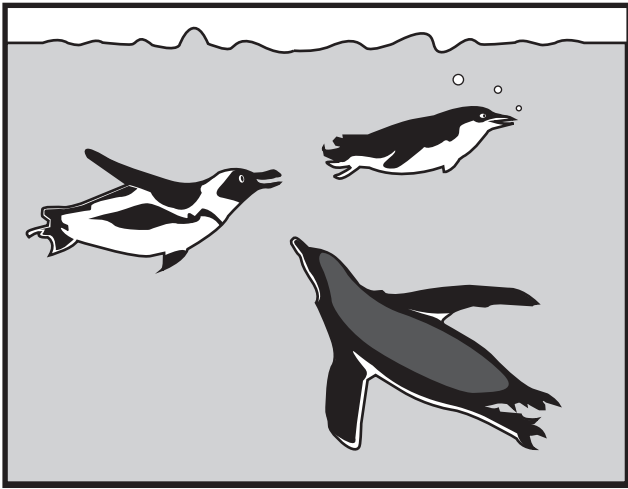

B. The penguins are playing.

*This is the fourth item of a six-part item. Student may not return to this item after responding to this item.*

**Item 31**

*This is the fifth item of a six-part item. Student may not return to the previous item after responding to this item.*

Which sentence is the end of your story?

*Point to each option as the TTS or TA reads each option.*



A. Noah likes to ride his bike to school.

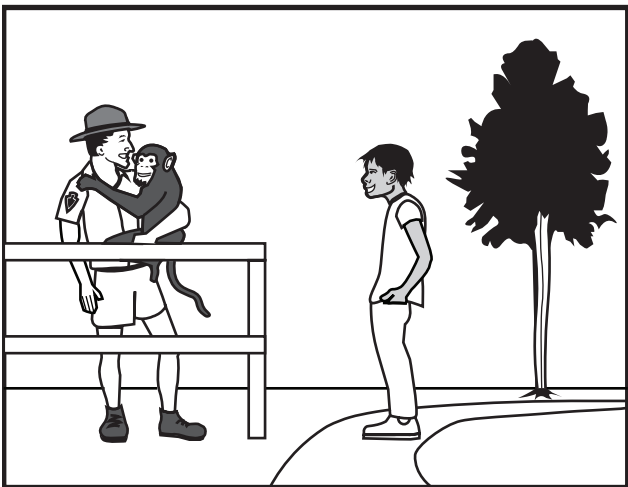

B. Noah has seen lots of animals at the zoo.

*This is the fifth item of a six-part item. Student may not return to this item after responding to this item.*

**Item 32**

*This is the sixth item of a six-part item. Student may not return to the previous item.*

The end of your story is “Noah has seen lots of animals at the zoo.”

You need a word or phrase to let the reader know that this is the end of your story.

Which words show that this is the end of your story?

*Point to each option as the TTS or TA reads each option.*

- A. By the end
- B. In the beginning

*Wait for student response. Then read the following:*

“By the end” tells the reader this is the end of your story.

So, the last sentence of your story is “By the end, Noah has seen lots of animals at the zoo.” Now your story is finished. Listen while your completed story is read to you.

*Point to Writing Stimulus 1, “A Trip to the Zoo” from the Grade 3 ELA Reference Materials and Writing Stimuli. Unmask all sentences of text and read the following statement.*

Noah wants to learn about animals. Noah is going to the zoo today. First, Noah visits the giraffes. Next, Noah watches the penguins. The penguins are playing. By the end, Noah has seen lots of animals at the zoo.

# You have reached the end of this Session.

## You may choose from the following options:

- Review items in this session
- **Pause** this test and **Resume** later
- Complete this session (**End Test**, then **Submit**) and begin Session 4

# Session 4

*Gather the stimulus materials for, “Preparing for Something,” and turn to page 91 to begin test administration. The stimulus materials can be found in the Grade 3 Practice Test ELA Reference Materials & Writing Stimuli provided by the School Test Coordinator.*

**Grade 3 Stimulus Materials List for Writing Stimuli 2: “Preparing for Something”**

**Card 1a:** For Great Grandma

**Card 2a:** Illustrations of “For Great Grandma”

**Card 3a:** Me

**Card 4a:** Blank character card

**Card 5a:** Blank activity card

**Card 6a:** Capital letters, end punctuation, and complete sentences

**Card 7a-8a:** Response Template

### Item 33

#### Directions

You are going to write a story about preparing for something. First, you are going to listen to a story about how Siu and her family prepare for great grandma's birthday party to give you some ideas for your story.

*Present Card 1a: For Great Grandma as the TTS or TA reads the story aloud.*

*Point to the illustrations from Card 2a from left to right as the story is read. The illustrations are indicated by superscripts in the passage on Card 1a and on the screen.*

#### For Great Grandma

One day, Siu's family prepares a party at the clubhouse. It is her great grandma's birthday. She is 100. Siu is very excited. Her whole family is coming to the party.

First, her family makes her great-grandma's favorite foods. The noodles are fun to make. Then Siu helps make dumplings.

Siu feels happy because she loves her great grandma. Siu wants to give her a nice gift. But there is no time to shop.

In the end, Siu uses her pens and paper to write great grandma in Chinese. Siu's great grandma is very happy with her gift.

*After reading Card 1a, move it and Card 2a to the side where the student can refer to them.*

In the story, Siu's family prepares for a party for her great grandma's birthday. Now you are going to write a story about preparing for something. You can either write about a time you prepared for something or make up a story about someone else who prepared for something.

In your story, you can include two events and tell about those two events.

*At this stage of the item administration, the TA will work with the student using the printed stimulus materials provided by the School Test Coordinator. If the student will enter the response in the DRC INSIGHT Assessment System, the student may type in the response areas on the screen instead of writing on Cards 7a and 8a.*

*Now remove Cards 1a and 2a.*



## Selection of a Character

*Present Card 3a.*

In the story we just read, one character is named Siu. First, you need to choose the character for your story. Is your story going to be about you or is it going to be about someone else?

*If the student selects someone else, go to the next question and present Card 4a.*

*If the student selects themselves, point to Card 3a and say the following statement:*

If you want it to be about you, pick this card.

Me

*Write “I” on Card 4a, point to it, and say the following statement:*

When you write about yourself, you can write “I.”

*Remove Card 3a. Move Card 4a to the side so the student can refer to it when writing. Go to Selection of the Activity below.*

*If the student picks someone else, remove Card 3a and present Card 4a. Say the following statement:*

You want the story to be about someone else. What is the name of the character in your story?

*Write the selected character’s name on Card 4a, read the name aloud to the student, and then move it to the side so the student can refer to it when writing.*

## Selection of the Activity

In the story we just read, Siu is helping to prepare for a party for her great grandma. What activity does [selected character] prepare for in your story?

*If the student PROVIDES an activity, write the selected activity on Card 5a. Go to the Writing the Story step.*

*If the student DOES NOT PROVIDE an activity, provide two options of activities that the student has helped prepare for. Say the following statement:*

Here are two activities that you prepared for. You will need to pick one activity your character prepares for in your story.

*Provide the two activities to the student.*

Which activity would you like to write about?

*Write the selected activity on Card 5a. Go to the Writing the Story step below.*

*NOTE: If the student DOES NOT SELECT an activity, the TA selects one of the two provided activities to which the student can write about. If the TA selects the activity, say the following statement:*

You need an activity that your character can prepare for. I will add [selected activity] to your story.

### **Writing the Story**

*Present Card 6a and cover the row showing the examples of capital letters. Point to each punctuation mark as you say the following statement.*

Good writing uses a period, exclamation point, or question mark at the end of each complete sentence.

*Point to “Good writers use complete sentences.” on Card 6a as you read the following statements.*

Good writers use complete sentences.

Remember to write complete sentences

*Point to the period in “Good writers use complete sentences.”*

and use correct punctuation.

*Move Card 6a to the side so that the student can refer to it when writing.*

*Point to the sentence starter “One day,” in the beginning section of Card 7a or the computer screen and say the following statement:*

Now that you have picked the character and an activity, you can start to write your story here.

*Point to the character’s name on Card 4a and the activity on Card 5a.*

This is your character and activity your character was preparing for.

*Point to the space following the first sentence starter “One day, \_\_\_\_\_” on Card 7a or the computer screen.*

Write your character’s name here.

*After the student writes, remove Card 4a, and say the following statement:*

Finish this sentence with the activity [selected character] prepares for.

*Read the sentence starter using an upward inflection in your voice at the end to indicate the student should complete the sentence.*

One day, [selected character] prepares for \_\_\_\_\_.

### **Describing the Situation**

In the story we just read, Siu helps her family prepare for a party for her great grandma. In this sentence, “clubhouse” tells where Siu is helping her family. Next, you can write where [selected character] prepares for [selected activity].

*Point to the second sentence starter “\_\_\_\_\_ prepares for \_\_\_\_\_ at” in the beginning section of Card 7a or the computer screen.*

Now, I will write your character and the activity in the beginning of the next sentence and read it to you.

*Write the name of the character and the new activity to start the second sentence.*

*Point to the second sentence on Card 7a or the computer screen and read the sentence using an upward inflection in your voice at the end to indicate that it is not a complete sentence.*

Finish this sentence to tell where [selected character] prepares for [selected activity].

*Read the sentence using an upward inflection in your voice at the end to indicate the student should complete the sentence.*

[selected character] prepares for [selected activity] at \_\_\_\_\_

*After the student writes, say the following statement:*

Now, I will read the beginning of your story to you.

*Read the student's Beginning.*

## **Describing the Events**

*Point to the middle section of Card 7a or the computer screen.*

You can write more information about what happens while [selected character] prepares for [selected activity] using details about the character's actions, thoughts, or feelings.

In the story we just read, first, Siu helps make her great grandma's favorite foods. The first event is Siu helps make food. The detail "carefully" describes how Siu helps make the food.

Now you can write about what happens first in your story. What event happened first in your story when [selected character] prepares for [selected activity]?

Remember to use details to describe your character's actions, thoughts, or feelings during the first event.

*Point to the sentence starter "First, \_\_\_\_\_" in the middle section of Card 7a or on the computer screen.*

Finish this sentence.

*Read the sentence starter using an upward inflection in your voice at the end to indicate the student should complete the sentence.*

First, \_\_\_\_\_

*After the student writes, say the following statement:*

I will read what happened first in your story.

*Read the student's response for the sentence starter "First, \_\_\_\_\_" on Card 7a or the computer screen.*

Now you can write about what happens next in your story.

In the story we read, the next thing Siu did was make noodles. The detail "fun" describes how Siu was feeling when making noodles.

Write about the next event that happened when [selected character] prepares for [selected activity]. Remember to use details to describe your character's actions, thoughts, or feelings during the next event.

*Point to the second sentence starter “Then, \_\_\_\_\_” in the top section of Card 8a or on the computer screen.*

Finish this sentence.

*Read the sentence starter using an upward inflection in your voice at the end to indicate the student should complete the sentence.*

Then, \_\_\_\_\_

## **Ending**

I will read what you have already written. Then you can write your ending.

*Point to and read the student’s Beginning and Middle on Cards 7a and 8a or the computer screen.*

Now you can write the last part of your story.

The ending of the story we just read was, “In the end, Siu uses her pens and paper to write great grandma in Chinese. Siu’s great grandma is very happy with her gift.”

*Point to the sentence starter “In the end \_\_\_\_\_” in the end section of Card 8a or on the computer screen.*

You wrote about [selected character] preparing for [selected activity]. Now, write the ending of your story. Finish this sentence to end your story.

*Read the sentence starter “In the end, \_\_\_\_\_” using an upward inflection in your voice at the end to indicate the student should complete the sentence.*

In the end, \_\_\_\_\_

## **Revising**

Now, I will read your story to you. Then you can revise your story. Remember, when you revise, you can add to or change your story.

*Point to and read the student’s Beginning, Middle, and End on Cards 7a and 8a or the computer screen.*

## Beginning

*Point to the beginning section on Card 7a or the computer screen with all sentences covered except for the first one. (Use the Masking Tool to cover the other sentences if using the DRC INSIGHT Assessment System instead of Cards 7a and 8a.)*

You were asked to write about a character that prepares for something in your story. I will read the beginning to you.

*Read the first sentence in the beginning section “One day, \_\_\_\_ prepares for \_\_\_\_” on Card 7a or the computer screen including the sentence starter.*

Is there anything you want to revise about the character or activity?

*If the student indicates no revisions, move to the next question.*

*If the student indicates revisions, the TA makes the revisions as given by the student on Card 7a or the computer screen. If the student indicates revisions, say the following statement:*

What revisions do you want to make to this sentence? I will make the changes for you.

*Uncover and point to the next sentence on Card 7a or the computer screen.*

You were asked to tell where your character helped prepare for something. You wrote:

*Read the student response “\_\_\_\_\_ prepares for \_\_\_\_\_ at \_\_\_\_\_” on Card 7a or the computer screen.*

Is there anything you want to revise about where your character prepares for something?

*If the student indicates no revisions, go to the Middle step below.*

*If the student indicates revisions, make the revisions as given by the student. If the student indicates revisions, say the following statement:*

What revisions do you want to make to this sentence? I will make the changes for you.

## Middle

*Uncover and point to the sentence starter “First,” in the middle section on Card 7a or on the computer screen.*

You were asked to include two events and describe what happened when your character, [selected character], prepares for [selected activity]. You were asked to use details about the character's actions, thoughts, or feelings. You wrote:

*Read the student response to "First, \_\_\_\_\_" on Card 7a or the computer screen including the sentence starter.*

Is there anything you want to revise about how you described the character's actions, thoughts or feelings during the first event?

*If the student indicates no revisions, move to the next question.*

*If the student indicates revisions, make the revisions as given by the student on Card 7a or the computer screen. If the student indicates revisions, say the following statement:*

What revisions do you want to make to this sentence? I will make the changes for you.

*Uncover and point to the sentence starter "Then," on the top section on Card 8a or the computer screen.*

For the second event, you were asked to use details to describe the character's actions, thoughts, or feelings. You wrote:

*Read the student response to "Then," on Card 8a or the computer screen, including the sentence starter.*

Is there anything you want to revise about how you described the character's actions, thoughts, or feelings during this event?

*If the student indicates no revisions, go to the Ending step.*

*If the student indicates revisions, make the revisions as given by the student on Card 8a or the computer screen. If the student indicates revisions, say the following statement:*

What revisions do you want to make to this sentence? I will make the changes for you.

## **Ending**

*Uncover and point to the sentence starter "In the end," on Card 8a or the computer screen.*

You were asked to write about what [selected character] prepares for (selected activity) to finish your story. You wrote:

*Read the student's response to "In the end," on Card 8a or the computer screen, including the sentence starter.*

Is there anything you want to revise to the end of your story?

*If the student indicates no revisions, go to the Editing step below.*

*If the student indicates revisions, make the revisions as given by the student on Card 8a or the computer screen. If the student indicates revisions, say the following statement:*

What revisions do you want to make to this sentence? I will make the changes for you.

## **Editing**

Next, you can edit your story.

*Present Card 6a and cover the row showing the examples of capital letters. Point to each punctuation mark as you say the following statement:*

Good writers use a period, an exclamation point, or a question mark at the end of each complete sentence.

*On Card 6a, point to "Good writers use complete sentences."*

Good writers use complete sentences. Remember to write complete sentences

*Point to the period in "Good writers use complete sentences."*

and use correct punctuation.

Now you can make edits to your story.

*If the student does not indicate any edits, go to the Read Story step.*

*If the student indicates edits, make the edits on Cards 7a and 8a or the computer screen.*

## **Read Story**

*Point to Cards 7a and 8a or the computer screen. If the student indicates revisions or edits to the final story as it is read, make the revisions or edits on the final copy. Only read the story once. Whatever is typed into the DRC INSIGHT Assessment System will be scored and is the final product.*



Now that you have finished making your revisions and edits, I will read your final story to you.

*Read the final story to the student.*

# You have reached the end of this Session.

## You may choose from the following options:

- Review items in this session
- **Pause** this test and **Resume** later
- Complete this session (**End Test**, then **Submit**)

**(page is intentionally blank)**

# **LEAP CONNECT**

**Practice Test**